

Panasonic

DVCPRO
DIGITAL VIDEO CASSETTE

Digital Camera/VTR

AJ-D700P

Operating Instructions

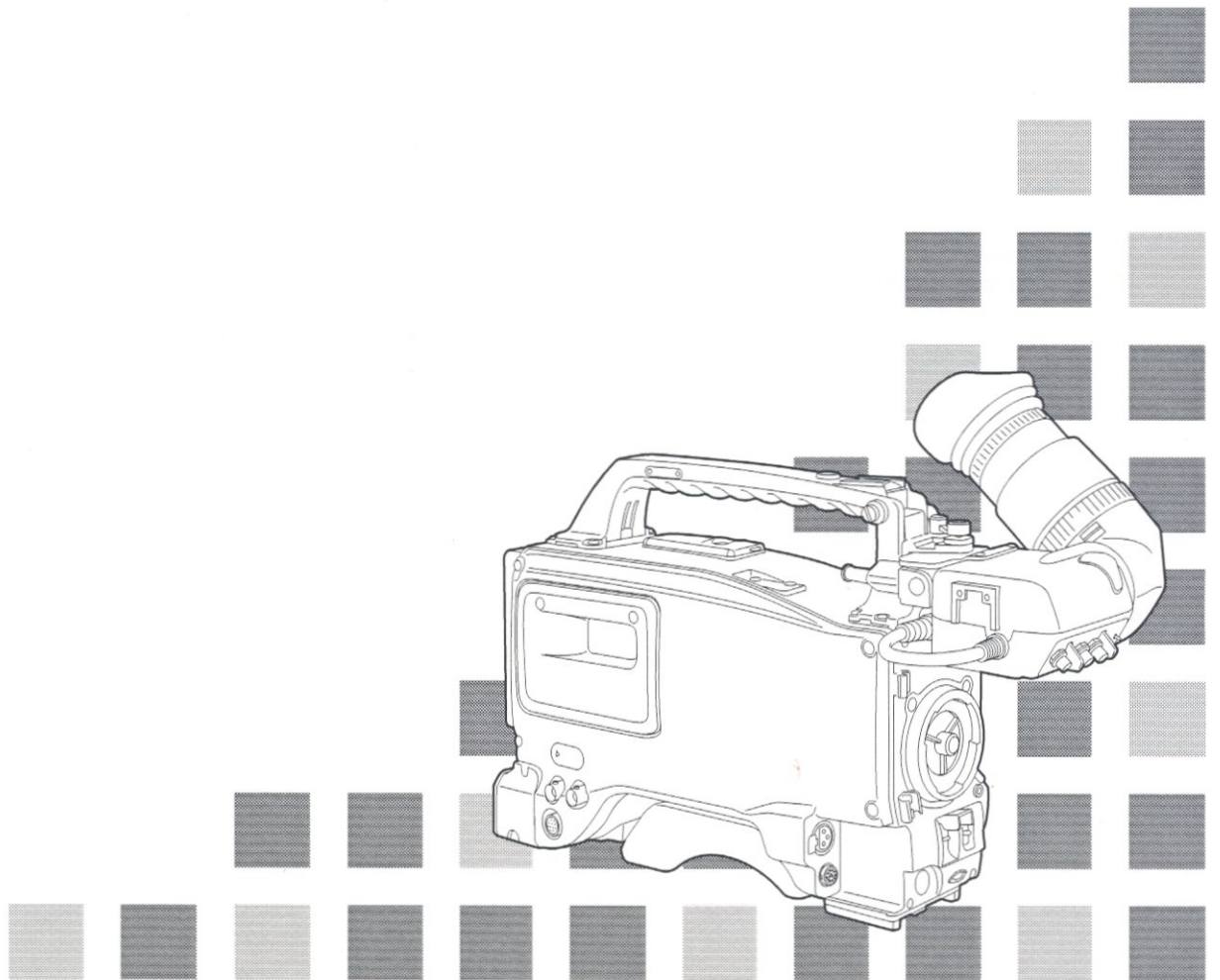

| | | |
|--|---|---|
|  | CAUTION RISK OF ELECTRIC SHOCK DO NOT OPEN |  |
| CAUTION TO REDUCE THE RISK OF ELECTRIC SHOCK, DO NOT REMOVE COVER (OR BACK) NO USER-SERVICEABLE PARTS INSIDE REFER SERVICING TO QUALIFIED SERVICE PERSONNEL | | |



The lightning flash with arrowhead symbol within an equilateral triangle, is intended to alert the user to the presence of uninsulated "dangerous voltage" within the product's enclosure that may be of sufficient magnitude to constitute a risk of electric shock to persons



The exclamation point within an equilateral triangle is intended to alert the user to the presence of important operating and maintenance (service) instructions in the literature accompanying the appliance

Replace battery with part No. CR2032 only
Use of another battery may present a risk of fire or explosion
Caution—Battery may explode if misreated
Do not recharge, disassemble or dispose of in fire

FCC NOTE

This device complies with Part 15 of the FCC Rules. To assure continued compliance follow the attached installation instructions and do not make any unauthorized modifications.

This equipment has been tested and found to comply with the limits for a Class A digital device, pursuant to Part 15 of the FCC Rules. These limits are designed to provide reasonable protection against harmful interference when the equipment is operated in a commercial environment. This equipment generates, uses, and can radiate radio frequency energy and, if not installed and used in accordance with the instruction manual, may cause harmful interference to radio communications. Operation of this equipment in a residential area is likely to cause harmful interference in which case the user will be required to correct the interference at his own expense.

CAUTION:
TO REDUCE THE RISK OF FIRE OR SHOCK HAZARD AND ANNOYING INTERFERENCE, USE THE RECOMMENDED ACCESSORIES ONLY

WARNING:
TO REDUCE THE RISK OF FIRE OR SHOCK HAZARD, DO NOT EXPOSE THIS EQUIPMENT TO RAIN OR MOISTURE

 is the safety information

Contents

| | | | |
|---|-----------|--|----|
| Safety Precautions | 2 | ● Using the AJ-MC700 Microphone Kit Microphone (Option) Mounted to the Main Unit | 37 |
| General and Features | 5 | ● Mounting the AJ-MH700P Microphone Holder (Option) | 38 |
| ● Features of the Camera Section | 5 | ● When using the microphone not mounted to the main unit | 39 |
| ● Features of the VTR Section | 8 | ● Mounting a Wireless Microphone | 41 |
| ● System Configuration | 9 | Connecting an Audio Component | 41 |
| Controls and Their Functions | | Mounting the Unit to a Tripod | 42 |
| ● Power Supply Section | 10 | Mounting the Shoulder Belt | 43 |
| ● Accessory Mounting Section | 11 | Adjusting the Shoulder Pad Position | 44 |
| ● Audio Function Section | 12 | Attaching the Rain Cover | 45 |
| ● Shooting (Recording)/Playback Function Section | 14 | Connecting the AQ-EC1 Extension Control Unit (Option) | 46 |
| ● Menu Operation Section | 20 | Warning/Status Displays in the Viewfinder and Display Window | |
| ● Time Code Related Section | 20 | ● Displaying the Setting Menu Inside the Viewfinder | 47 |
| ● Warning/Status Display Section | 22 | ● Setting Menu Configuration | 48 |
| Power Supply Preparations | | ● Basic Setting Menu Operations | 49 |
| ● Using an Anton Bauer Battery Pack | 23 | Lamp Displays Inside the Viewfinder | |
| ● Using the Panasonic AU-BP402 Battery Pack | 24 | ● Lamp Display Configuration Inside the Viewfinder | 51 |
| ● Using a Sony Battery Pack | 26 | ● Setting the ! Lamp Display | 52 |
| ● Using an AC Power Supply (When Using the AU-B110 AC Adaptor) | 28 | Status Displays on the Viewfinder Screen | |
| Mounting the Lens | 29 | ● Status Display Configuration Inside the Viewfinder Screen | 53 |
| Adjusting the Flange Back | 30 | ● Selecting Display Items | 56 |
| Adjusting the White Shading | 31 | ● Display Mode and Setting Change Messages | 57 |
| Adjusting the Viewfinder | | ● Setting the Marker Display | 58 |
| ● Adjusting the Position | 33 | ● Setting the Camera ID | 59 |
| ● Adjusting the Diopter and Screen | 34 | | |
| ● Adjusting the Eyecup Position | 34 | | |
| ● Detaching the Eyecup | 35 | | |
| ● Detaching and Mounting the Viewfinder | 36 | | |
| Audio Input Preparations | | | |
| ● Using the Microphone Mounted to the Main Unit | | | |

Bold letters should be set or adjusted immediately after purchase.

Contents

| | | | |
|--|----|--|-----|
| Displays | | Cassettes | |
| • Remaining Battery Level and Audio Level Displays | 60 | • Inserting and Ejecting Cassettes | 87 |
| • VTR Section Operation/Status-Related Displays | 60 | • Preventing Accidental Erasure | 88 |
| • Time Code-Related Displays | 61 | Recording | |
| • Adjusting the Time and Date | 62 | • Basic Procedures | 89 |
| Adjustments and Setup using the Setting Menu | 63 | • Successive Shooting | 92 |
| • Setting the Gain Selector Value | 64 | Playback—Checking Recorded Contents | |
| • Selecting Functions | 65 | • Rec Review | 94 |
| Adjusting the Black Balance/White Balance | | • Color Playback | 94 |
| • Adjusting the White Balance | 66 | Connection With an External VTR | 95 |
| • Adjusting the Black Balance | 69 | Recording Simultaneously with the Internal VTR and an External VTR | 96 |
| Setting the Electronic Shutter | | Recording With an External VTR Instead of the Internal VTR | |
| • Shutter Mode | 71 | • Using the 26-pin Output Adapter | 98 |
| • Selecting the Shutter Mode/Speed | 72 | Setting Menu Screens | 102 |
| • Setting the Synchro scan and SUPER V Modes | 73 | Warning System | 124 |
| • Changing the Shutter Mode/Speed Selection Range | 74 | Error Code | 126 |
| Changing the Reference Value for Iris Automatic Adjustment | 74 | Condensation | 126 |
| Adjusting the Audio Level | 75 | Maintenance | |
| Setting the Time Data | | • Cleaning the Video Heads | 127 |
| • Setting the Time Code | 77 | • Cleaning the Viewfinder | 127 |
| • Setting the User Bit | 78 | • Characteristic Phenomenon of CCD Cameras | 127 |
| • Locking the Time Code to an External Source | 79 | Inspections Before Shooting | |
| Setup Card Operations | | • Inspection Preparations | 128 |
| • Setup Card Handling | 81 | • Inspecting the Camera Section | 128 |
| • Setup Card Data Operations | 82 | • Inspecting the VTR Section | 130 |
| | | Specifications | |
| | | • Camera Section | 133 |
| | | • VTR Section | 134 |
| | | • Accessories | 134 |
| | | • Related Components | 135 |

General and Features

The model AJ-D700 integrates a color video camera which employs three frame interline transfer (FIT) CCDs with 410,000 device on-chip lenses with a DVCPRO format VTR which is equipped with the latest compression technology

The AJ-D700 is particularly compact and light weight with low power consumption, and realizes the optimal functions and performance for an electronic news gathering (ENG) VTR-integrated camera such as high picture quality and sensitivity, mobility, dustproofing and dampproofing, etc. In addition, both the camera section and the VTR employ a digital signal processing system which further improves picture quality and realizes a system for controlling setting menu and subject data by using world standard memory cards

Camera Section Features

The camera section of the AJ-D700 has the following features

- High sensitivity 2000 lux (FB)
- High S/N ratio 62 dB (standard)
- Ultra-low smear
- Ultra-low flare

Digital signal processing

Signal processing is digitized by a 14.3 MHz/28.6 MHz (typ.) 10-bit AD/DA converter. This improves picture quality, stability and reliability, and allows the viewfinder screen displays as well as numerous adjustment and setup items to be converted to menus

Setting menu

The setting menu is displayed on the viewfinder screen, and controls the status displays, messages, marker displays, etc. Whether or not to display each item, as well as the display conditions when items are to be displayed, can be selected according to the user's convenience. For example, display ON/OFF for the lamp display which informs the user that the unit has entered irregular status can be selected for 7 different conditions

The setting menu is also used to select various settings and functions and execute memory card operations, etc.

Setup cards

Setting menu and subject data can be stored on SRAM memory cards with a capacity of 64 kilobytes or greater which conform to PCM CIA standard ratings as setup cards. Stored data can be saved individually or according to the shooting conditions, allowing the same setup conditions to be easily reproduced and assisting in standardizing setup conditions between individual data

High-function electronic shutter

Using the built-in electronic shutter achieves steady images even of quickly moving subjects. In addition, the following special operation modes can also be selected

- Synchro scan mode: This mode is suited for shooting personal computer and workstation monitor screens, and provides images with little horizontal stripe noise
- High vertical resolution (Super V) mode: This mode provides images with high vertical resolution compared to standard mode

Wide range of video gain selections

Eleven gain values can be selected from -3 dB to +30 dB using the setting menu and the GAIN switch. The high S/N ratio allows images with little noise to be obtained even when the gain is increased for shooting in dark locations

Automatic adjustment and memory functions for black balance/white balance

The black set, black balance and white balance can be automatically adjusted by simple switch operations. Adjustment values are held in the memory even if the power for the unit is turned off, so there is no need to readjust the balance each time the power is turned on

There are two memory systems for white balance which can hold four adjustment values each for the CC and ND filters, making a total of eight adjustment values. When adjustment values matching the illumination conditions are selected from among the values stored in the memory, the unit is automatically adjusted to the corresponding white balance. (A menu setting also allows adjustment of only two values instead of the values for each filter.) In addition, when the unit is shipped from the factory, the white balance value for 3200K is stored in the memory as a preset value. This value can be called when there is no time to adjust the white balance, etc.

Features

High-performance viewfinder

- The high-resolution CRT projects a detailed picture which facilitates focus operations
- The viewfinder employs a low flare CRT which makes the screen easy to see
- A center marker which indicates the center of the screen and a safety zone marker which indicates the effective screen region can be displayed by menu operations
- A large aperture allows the screen to be easily seen even when the operator's eye is removed from the eyepiece
- The eyepiece can easily be detached. When the eyepiece is detached, the center of the screen will not become blurred even when viewed from a distance. This also facilitates the removal of dust which has adhered to the CRT screen and mirror
- One-touch position adjustment is possible not only in the right-left direction but also in the forward-backward direction

Character display function

The unit is equipped with a function that displays switch settings, the automatic adjustment status for black balance and white balance, warning displays, etc. on the viewfinder screen. In addition, when using an Anton Bauer Digital Magnum series battery as the unit's power supply, the remaining battery level can be displayed numerically on the viewfinder screen.

Warning system for displaying the VTR section status

The unit informs of VTR trouble, the end of the tape, battery wear, etc. with various warning lamps and a warning tone. The remaining tape time can also be checked by the character display inside the viewfinder.

Four filter disks as standard equipment

CC (color temperature conversion) and ND (neutral density) filters are provided as standard equipment. This allows the optimal filter setting to be selected from among four combinations in accordance with the brightness of the subject.

Fine adjustment of the automatic iris reference value

The reference value for automatic iris adjustment can be finely adjusted by setting menu operations.

Auto close function

The unit is equipped with an auto close function which automatically closes the lens in the following cases:

- When the black balance is automatically adjusted
- When the power is turned off in the auto iris mode

Generation of SMPTE color bar and reference audio signals

The camera section contains a circuit which generates an SMPTE type color bar signal to facilitate color monitor adjustments, and a circuit which generates a reference level audio signal to facilitate audio level adjustments.

Functions and circuits for assuring high picture quality

The AJ-D700 is equipped with the following functions (and circuits) in order to assure high picture quality and is designed to make the fullest use of the advantages of the high-performance CCD.

- A built-in AUTO KNEE circuit achieves a wide dynamic range which allows large signals to pass through
- A built-in 2-line image enhancer
- A built-in shading compensation function for use with a lens extender
- A built-in sawtooth wave generator for adjustments
- A zebra pattern ON/OFF selector switch which selects three types of zebra patterns including spot zebra from two levels of zebra patterns

Audio functions

- A phantom power supply type super-cardioid microphone (option) can be attached and it can also be detached from the main unit for use in interviews
- Microphone can also be connected, and can be attached to the main unit using the AJ-MH700P microphone holder (option)
- The audio CH1 recording level can be easily adjusted at the front panel of the unit

Recording by an external VTR

When an external VTR is connected using the 26-pin output adaptor (option, AJ-YA700P), recording can be performed by the external VTR instead of the internal VTR

Remote control

Connecting the Extension Control Unit (option, AQ-EC1) allows a portion of the camera section functions to be operated by remote control

Features

Features of the VTR section

Digital system

The VTR section features a component digital recording system that employs the latest compression technology and non-compressed PCM recording for audio. This system provides superior S/N, frequency band and waveform characteristics as well as reproduction of detailed areas, etc., and realizes even higher picture and sound quality.

Rec review function

This function automatically rewinds the tape and plays back the last two seconds recorded, allowing recorded contents to be quickly checked.

Playback function

Playback pictures (black-and-white pictures) can be seen on the viewfinder screen. In addition, color playback pictures can be seen on a color monitor connected to the VIDEO OUT connector on the main unit.

Built-in time code generator/reader

Time code information can be recorded and played back on a dedicated subcode track.

Locking of the time code to an external source

The built-in time code generator can be locked to an external generator. Also, the built-in time code generator uses a lithium battery as its back-up power supply, allowing time codes to be backed up for approximately one year even if power is not supplied to the unit.

Built-in DOLBY NR System*

A Dolby B Noise Reduction System is built in for audio recording in the longitudinal direction.

Successive shooting

Images can be shot successively within an accuracy of ± 1 frame can be performed simply by pressing the VTR START button or the lens VTR button.

*Dolby noise reduction manufactured under license from Dolby Laboratories Licensing Corporation. "Dolby" and the double-D symbol  are trademarks of Dolby Laboratories Licensing Corporation.

System Configuration

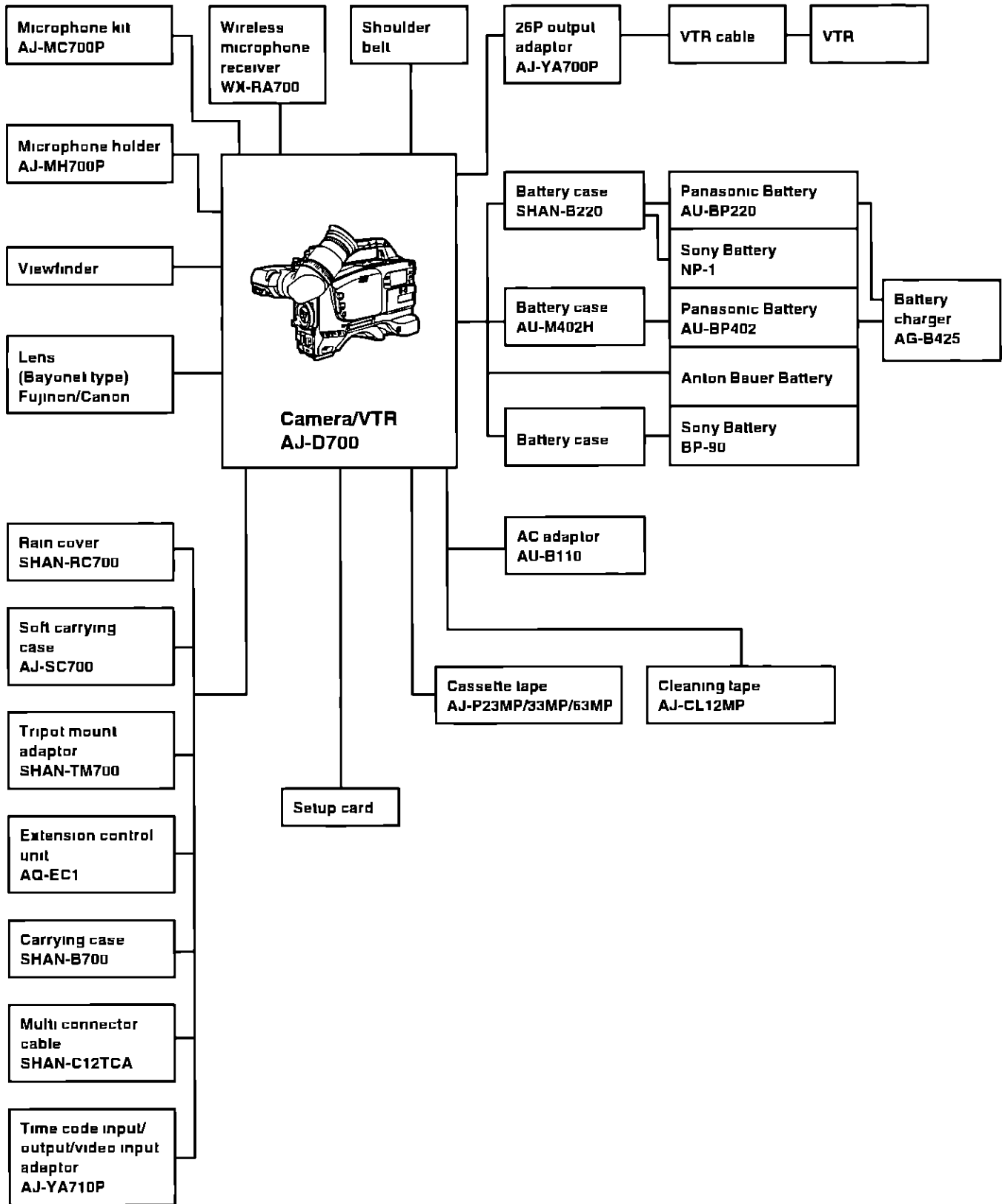

Controls and Their Functions

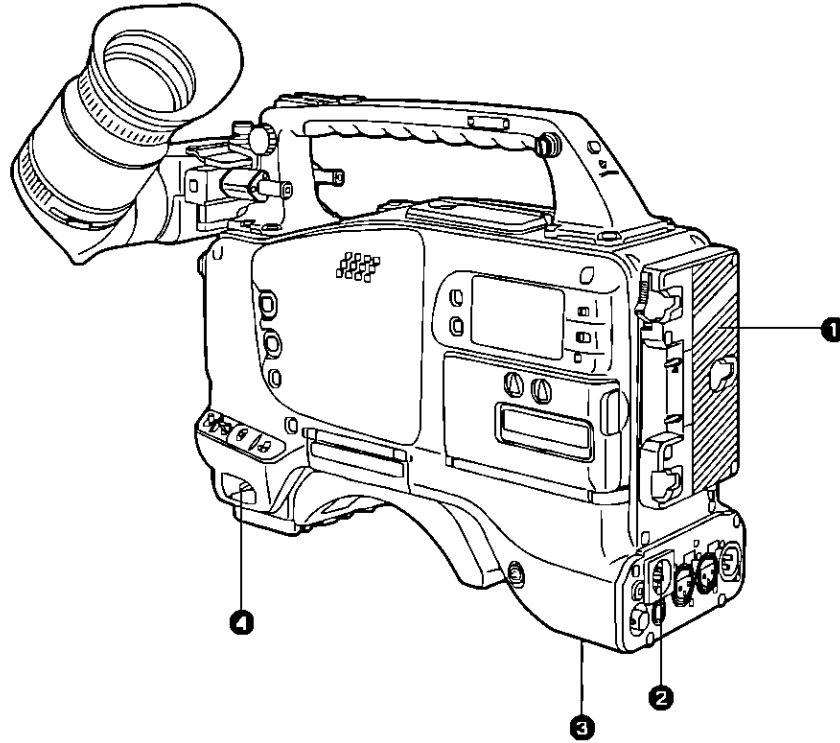

Power Supply Section

- ❶ Battery holder**
The battery pack (option) made by Anton Bauer is mounted onto this holder
- ❷ DC IN (external power input) connector (XLR, 4P)**
The AU-B110 AC adaptor (option) is plugged into this socket when the unit is to be operated by AC power. An external battery is plugged in when an external battery is to be used to operate the unit
- ❸ BREAKER (circuit breaker) button**
In order to protect the equipment, the circuit breaker is tripped and the power is automatically turned off when an excessively high level of power flows inside. Upon completion of the internal inspection and adjustments, push this button back in. The power will come back on provided that there is no trouble inside the unit
- ❹ POWER switch**
ON Set to this position to turn on the unit's power
OFF Set to this position to turn off the unit's power

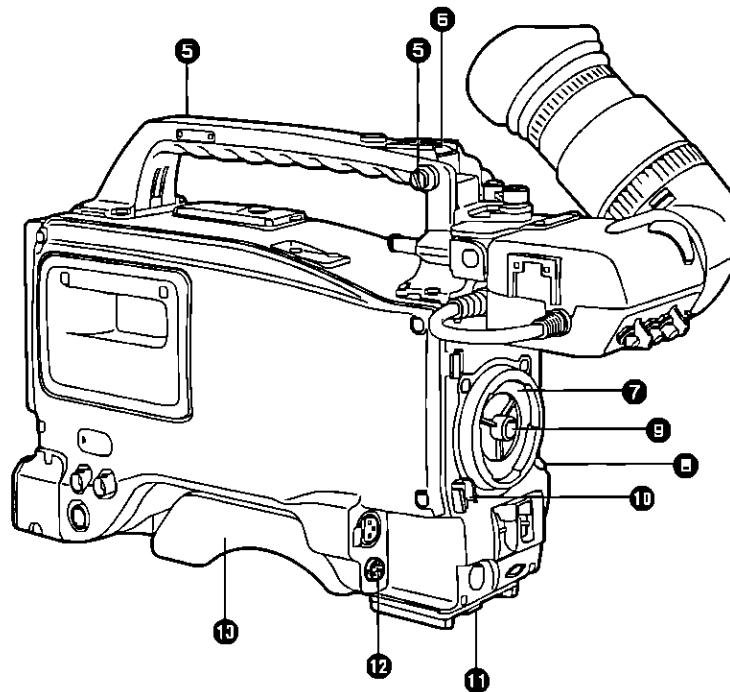

Accessory Mounting Section

- 5 Hook for mounting shoulder belt**
Attach the accessory shoulder belt to this hook
- 6 Light shoe**
Mount the video light, etc. onto this shoe
- 7 Lens mount (bayonet type)**
Mount the lens here
- 8 Lens clamping lever**
Insert the lens into the lens mount **7**, and turn the lens mount ring using this lever to clamp the lens
- 9 Lens mount cap**
Press up the lens clamping lever **8** to remove this cap. Keep the cap in place if the lens is not going to be mounted
- 10 Lens cable clamp**
This is for clamping the lens cable
- 11 Tripod mount**
When the unit is to be secured to a tripod, mount the optional tripod attachment
- 12 LENS connector (12-pin)**
Hook up the lens connecting cable to this connector. Consult with your dealer concerning the lens which you are going to use
- 13 Shoulder pad**
Adjust this pad to facilitate operation when carrying the unit on your shoulder. Its position can be brought forward or backward and adjusted by loosening the two set screws

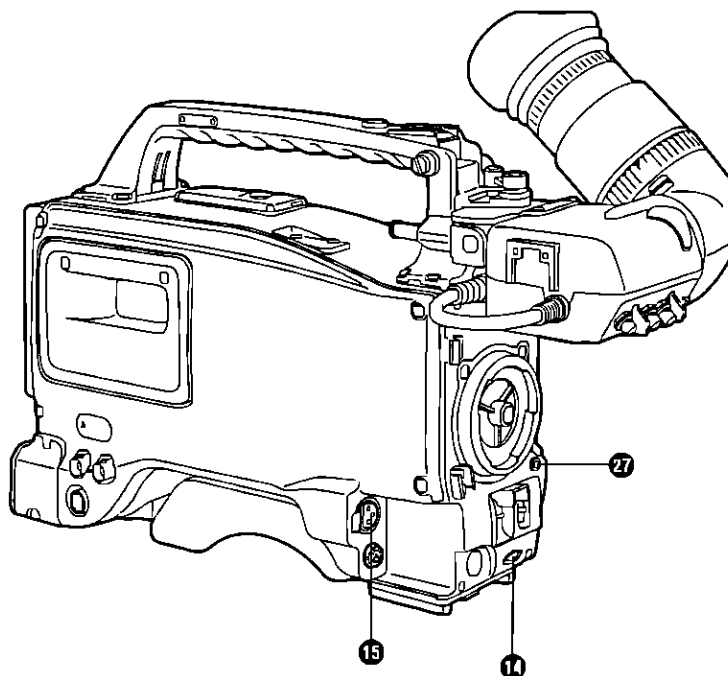

Audio Function Section (1)

- 17 AUDIO LEVEL CH1 (audio channel 1 recording level) control**
When the AUDIO SELECT CH1/CH2 switch **17** is set to MAN, the recording level of audio channel 1 can be adjusted by this control in addition to the AUDIO LEVEL CH1 control **15** on the side panel
- 15 MIC IN (microphone input) jack (XLR, 3-pin)**
Connect an optional microphone to this jack. The power for the microphone is supplied from this jack.

Audio Function Section (2)

- 17 AUDIO LEVEL CH1/CH2 (audio channel 1/2 recording level) controls**
When the AUDIO SELECT CH1/CH2 switch **17** is set to MAN, the audio level of audio channels 1 and 2 can be adjusted using these controls.
However, the audio CH1 level can also be adjusted using the AUDIO LEVEL CH1 control **15** on the front panel.
- 17 AUDIO SELECT CH1/CH2 switch (audio channel 1/2 auto/manual level adjustment selector) switch**
This selects the method used to adjust the audio levels of audio channels 1 and 2.
AUTO For adjusting the levels automatically
MAN For adjusting the levels manually
- 17 AUDIO IN (audio input selector) switch**
This selects the input signals to be recorded on audio channels 1 and 2.
FRONT [MIC] The microphone input signals connected to the MIC IN jack **15** are recorded.
REAR [MIC] The microphone input signals connected to the AUDIO IN CH1/CH2 connectors **19** are recorded.
REAR [LINE] The line input signals connected to the AUDIO IN CH1/CH2 connectors **19** are recorded.
- 19 AUDIO IN CH1/CH2 (audio input channel 1/2) connectors (XLR, 3P)**
An audio component or microphone is connected here.
- 20 AUDIO OUT connector (XLR, 3P)**
This is connected to an audio component. The audio channels can be selected on the setting menu.
- 21 DC OUT (DC power output) connector**
This is the DC 12 V output connector. A current of approximately 100 mA can be taken out.

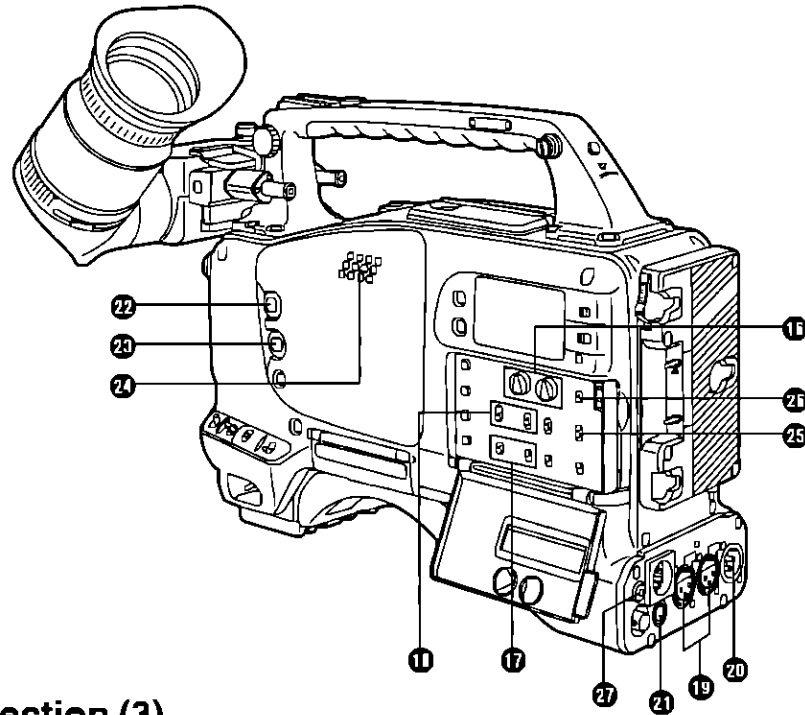

Audio Function Section (3)

22 ALARM (warning tone volume) control

This adjusts the warning tone volume heard from the speaker 24 or the earphone connected to the PHONES jack 27. When it is set to the lowest position, the warning tone is not audible. However, by making changes to the inside parts, the tone can be made audible even when the control is at its lowest position.

26 MONITOR (volume) control

This adjusts the volume of the sound other than the warning tone—the sound from the speaker 24 or earphone 27. When it is set to the lowest position, no sound is heard.

Audio Function Section (4)

24 Speaker

During recording, the EE sound can be monitored, during playback, the playback sound can be monitored.

The warning tone is heard through the speaker in synchronization with the flashing or lighting of the warning lamp and warning display.

The speaker sound is automatically muted when an earphone is connected to the PHONES jack 27.

25 MONITOR SELECT (audio channel selector) switch

This selects the audio channel whose sound is to be heard through the speaker 24 or earphone.

CH1 The audio channel 1 sound is output.

CH1, 2 The sound produced by mixing the audio channel 1 and 2 sound or the stereo sound is output. However, only the mixed sound is output from the speaker 24.

CH2 The audio channel 2 sound is output.

26 MONITOR (sound selector) switch

This selects the sound of the earphone when CH1, 2 is selected with the MONITOR SELECT switch 25.

27 PHONES (earphone) jack (mini-jack)

When an earphone (option) is connected to this jack, the sound selected by the MONITOR switch 26 can be heard. The warning tones relating to the unit's operation or status can also be heard. An earphone enabling a sufficiently high volume of sound to be heard is recommended. When the earphone is connected, speaker 24 sound is automatically muted.

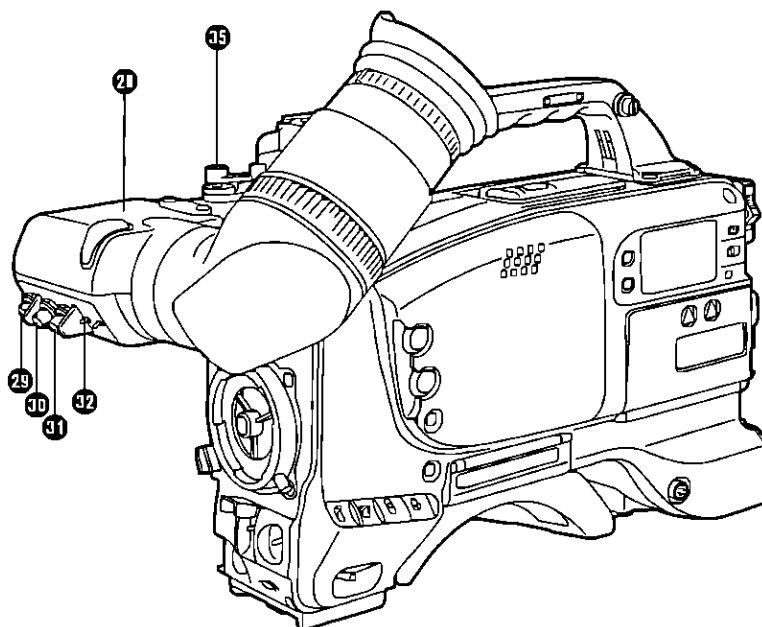

Shooting (Recording)/Playback Function Section (1)

- 21 Viewfinder**
Black-and-white images can be seen in the viewfinder during recording and playback. Warnings and messages relating to the unit's operating status and settings, zebra pattern, markers (safety zone marker, center marker), etc. can also be seen.
- 23 PEAKING control**
This is used to adjust the contours of the images inside the viewfinder to facilitate focusing. It does not affect the camera's output signals.
- 29 CONTRAST control**
This is used to adjust the contrast of the screen inside the viewfinder. It does not affect the camera's output signals.
- 30 BRIGHT control**
This is used to adjust the brightness of the screen inside the viewfinder. It does not affect the camera's output signals.
- 31 ZEBRA (zebra pattern) switch**
This displays the zebra pattern inside the viewfinder.
ON The zebra pattern is displayed.
OFF The zebra pattern is not displayed.
When the unit is shipped from the factory, the zebra pattern is set in such a way that those parts with an IRE video level from approx. 70% to 85% are displayed. The displaying of parts with a level ranging from 50% to 110% or more or with a certain level can also be set on the setting menu.
- 32 Diopter control knob**
This is adjusted in such a way that the images on the viewfinder screen are seen most clearly in accordance with the dioptric power of the camera's operator.
- 33 Eye cup**
- 34 Viewfinder forward-backward/left-right position clamp lever**
Loosen this lever to adjust the position of the viewfinder **21** in the forward-backward or left-right direction.
- 35 Eyecup forward-backward movement ring**
Turn this ring to adjust the position of the eyecup **21** in the forward-backward direction.
- 37 Viewfinder stopper screw**
To detach the viewfinder **21** from the camera, loosen this screw and then detach the viewfinder.

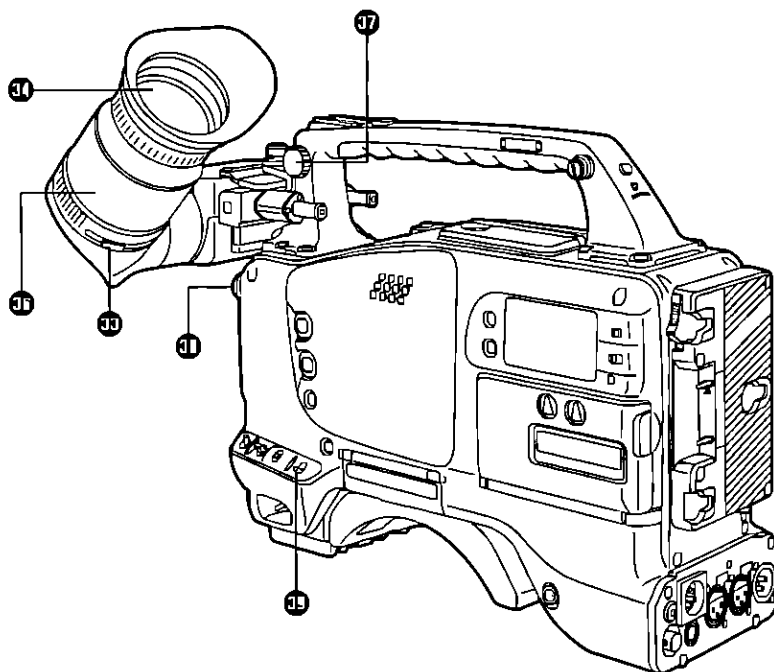

Shooting (Recording)/Playback Function Section (2)

20 CC/ND FILTER (filter selector) knob

This selects the filter to match the light source which is illuminating the subject. If the setting of this knob is changed when the menu display mode has been set to "3" (default setting), the new setting will appear for about 3 seconds on the setting change message display area of the viewfinder screen.

■ The knob and filter settings are listed below

| FILTER knob setting | Description |
|---------------------|--------------|
| 1 | 3200K |
| 2 | 5600K+1/4ND |
| 3 | 5600K |
| 4 | 5600K+1/16ND |

■ Examples of filter settings to match shooting conditions

| Filter | Shooting condition |
|--------|---|
| 1 | Sunrise, sunset, inside a studio |
| 2 | Outdoors under a clear sky |
| 3 | Outdoors under a cloudy or rainy sky |
| 4 | Snow scenes, high mountains, coastlines and other extremely clear and bright scenes |

21 WHITE BAL (white balance memory selector) switch

PRST Set to this position when there is no time to adjust the white balance. The white balance value for 3200K is stored in the memory.

A or B When the AUTO W/B BAL switch 22 is pressed to the AWB side, the white balance is automatically adjusted in accordance with the setting position of the filter knob 20, and the adjustment value is stored in memory A or memory B.

When the FILTER knob and the WHITE BAL switch are set to the same positions as the ones set when the adjustment was made, the adjustment value stored in the memory is called, and the unit is automatically adjusted to the white balance which corresponds to this value.

If the setting of this switch is changed when the menu display mode has been set to "3" (default setting), the new setting will appear for about 3 seconds at the WHITE BAL switch display position on the viewfinder screen. (Example "W A")

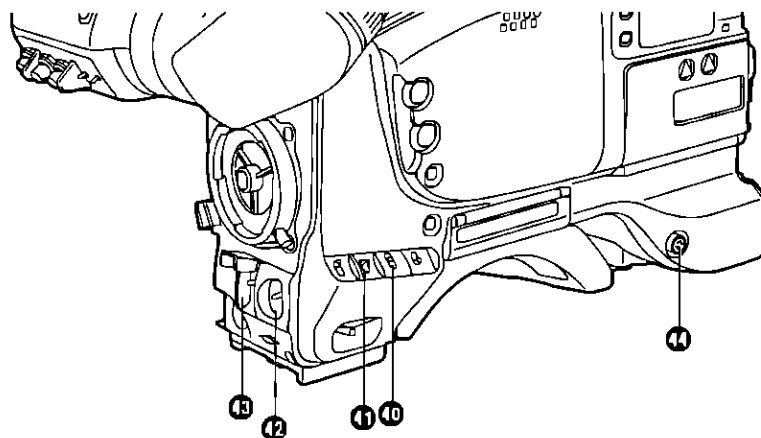

Shooting (Recording)/Playback Function Section (3)

⑩ OUTPUT (output signal selector)/AUTO KNEE switch

This switch selects the video signals which are to be output from the camera unit to the VTR unit, viewfinder and video monitor. The AUTO KNEE function can be used when the images shot by the camera have been selected.

■ OUTPUT/AUTO KNEE switch setting positions

| | |
|--------------------|--|
| BARS | Color bar signals are output. The AUTO KNEE circuit is not activated. Set the switch to this position in the following cases: <ul style="list-style-type: none"> When adjusting the video monitor When recording color bar signals |
| CAM, AUTO KNEE OFF | The images shot by the camera are output. The AUTO KNEE circuit is not activated. The default setting is "MANUAL KNEE". |
| CAM, AUTO KNEE ON | The images shot by the camera are output. The AUTO KNEE circuit is activated. |

⑪ GAIN (gain selector) switch

This is used to change the video amplifier's gain in accordance with the lighting conditions during shooting. The gain values corresponding to the L, M and H settings are assigned beforehand on the setting menu. When the unit is shipped from the factory, these settings are L=0 dB, M=9 dB and H=18 dB.

If the setting of this switch is changed when the menu display mode has been set to "3", the new setting will appear for about 3 seconds at the gain display position on the viewfinder screen. (Example "12 dB")

⑫ AUTO W/B BAL (white balance/black balance automatic adjustment) switch

AWB Set to this position for automatically adjusting the white balance. When the WHITE BAL switch ⑬ is now set to "A or B", the adjusted value will be stored in memory A or memory B.

ABB Set to this position for automatically adjusting the black balance. The adjusted value will be stored in the dedicated memory.

⑬ SHUTTER switch

Set this to ON when using the electronic shutter. When it is pressed to the SEL side, the shutter speed and mode displays change in the ranges preset on the setting menu. If the setting of this switch is changed when the menu display mode has been set to "2" or "3", the new settings will appear for about 3 seconds at the shutter display position on the viewfinder screen. (Example "1/250", "1/617")

1) AUTO KNEE function

When the level is adjusted to people, scenes, etc. for shooting against a very bright background, the background will be whited out and the buildings or scenes in the background will become blurred. If the AUTO KNEE function is activated in cases like these, the background can be reproduced in clear detail. This function is especially effective for shooting in the following conditions:

- When shooting people in shade under a clear sky
- When simultaneously shooting people in vehicles or indoor and the outdoor scenery seen through the windows
- When shooting scenes with a high contrast

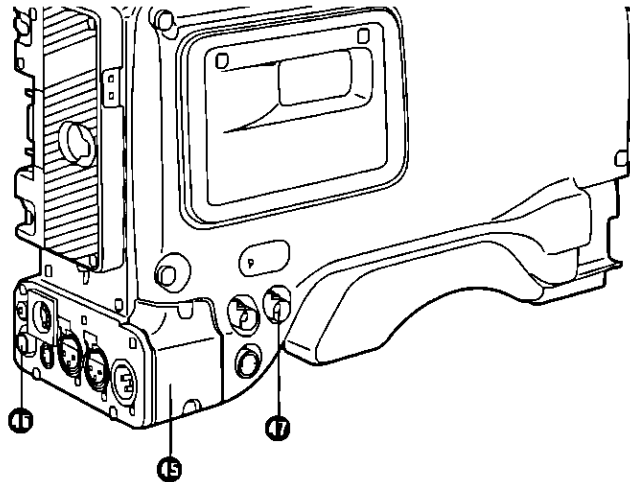

14 ECU REMOTE (remote control) connector (6-pin)

Connect the AQ-EC1 extension control unit (option) here

<Note>

The POWER switches on unit and extension control unit must be set to OFF before the remote control cable is connected or disconnected

15 VIDEO IN connector (accessory)/26-pin output adaptor (option) mount

VIDEO IN connector (accessory) (See below for the mounting method)

The composite video signals are supplied here. It is used for checking the return signal and recording external input signals

<Note>

When recording signals input from an external source, recording can only be assured for standard signals

26-pin output adaptor (option) (See page 98 for mounting method)

The 26-pin output adaptor AJ-YA700P (option) is mounted on this section. When the portable VTR is connected as the external VTR, recording can be performed simultaneously with the unit's built-in VTR

16 VIDEO OUT connector (BNC)

This outputs the video signals (75Ω termination, rated level) to be monitored. During recording, EE images can be monitored, during playback, playback images can be monitored

While performing settings on the menu, the setting menu can be superimposed onto the shot images appearing on the monitor screen so that the settings can be checked (in which case, the images appear in black and white)

17 CAM OUT (camera output) connector (BNC)

This outputs the composite video signals (75Ω termination, rated level). When a video monitor is connected, the images shot by the camera can be monitored. Even while the VTR is playing back, the camera's images are output at all times

Mounting the VIDEO IN connector

Remove the blank panel and mount the VIDEO IN connector

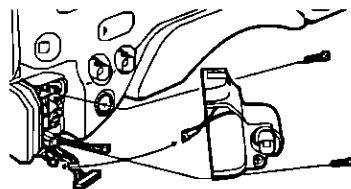

Connect the 2P connector

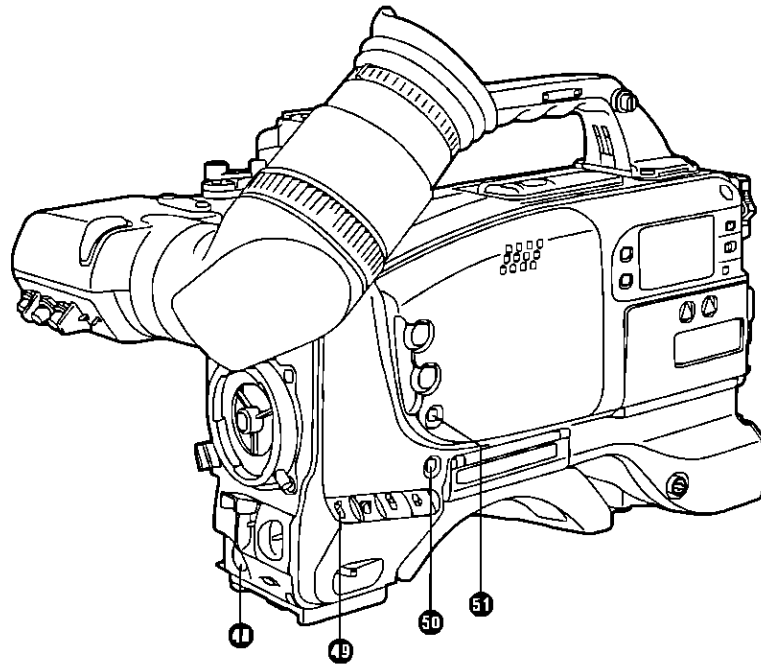

Shooting (Recording)/Playback Function Section (4)

④ VTR START button

When this is pressed, recording commences, when it is pressed again, recording stops. This button has the same function as the VTR button on the lens side.

④ VTR SAVE/STBY (tape protection) switch

This selects the power supply status while the VTR recording is temporarily stopped (REC PAUSE).

SAVE This is the tape protection mode. The cylinder is stopped in the half-loading status. Compared with the STBY position, less power is consumed and the unit can be operated longer using the battery. It takes longer for recording to commence after the VTR START button ④ is pressed in the SAVE position than in the STBY position. When the switch is set to this position, the VTR SAVE lamp inside the viewfinder lights.

STBY Recording commences immediately when the VTR START button is pressed.

⑤① MODE CHECK button

While this button is kept depressed, the camera's setting status is displayed in the viewfinder. It does not affect the camera's output signals. This button can also be used for fine adjustment at the setting menu during synchro scan mode.

⑤② SUPER IRIS button

This is used when backlight compensation is to be provided. When it is pressed, the switch settings are displayed inside the viewfinder for 3 seconds. When it is pressed again, backlight compensation is released.

Whether the super gain (30 dB) mode or the super iris (backlight compensation) mode is to apply can be selected on the setting menu. This button can also be used for fine adjustment during synchro scan mode.

Super gain When 30 dB is allotted to the SUPER IRIS button, DTL and other menu settings cannot be performed for this 30 dB.

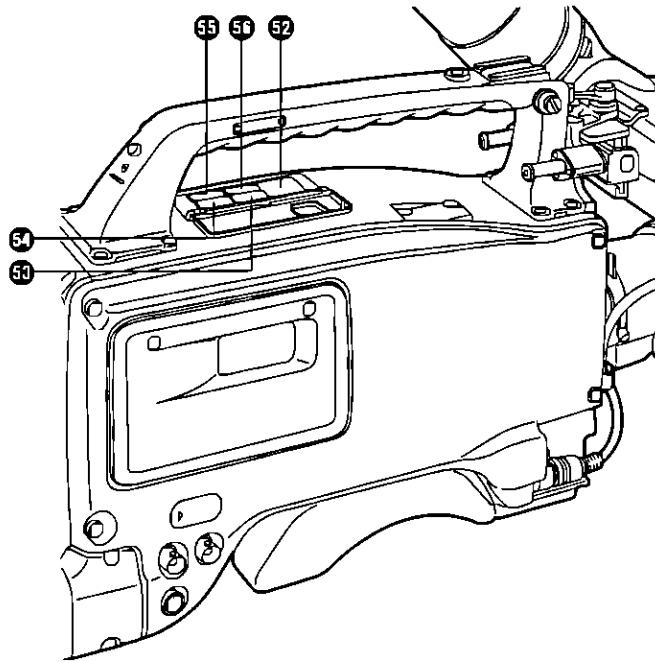

- 52 EJECT (cassette eject) button**
 Press this to insert or eject the cassette
- 50 REW (rewind) button**
 Press this to rewind the tape. Its lamp lights during rewinding.
 If this button is pressed during playback, the playback images are rewound at approximately quadruple speed while the button is held down.
- 54 FF (fast forward) button**
 Press this to fast forward the tape. Its lamp lights during fast forwarding.
 If this button is pressed during playback, the playback images are fast forwarded at approximately quadruple speed while the button is held down.
- 55 PLAY (playback) button**
 Press this to view the playback images on the viewfinder screen or color video monitor. Its lamp lights during playback.
 If this button is pressed again during playback, playback is paused and the lamp goes off. After playback has been paused for 5 minutes, the unit automatically switches to stop status (STOP).
- 51 STOP button**
 Press this to stop the tape travel.

Controls and Their Functions

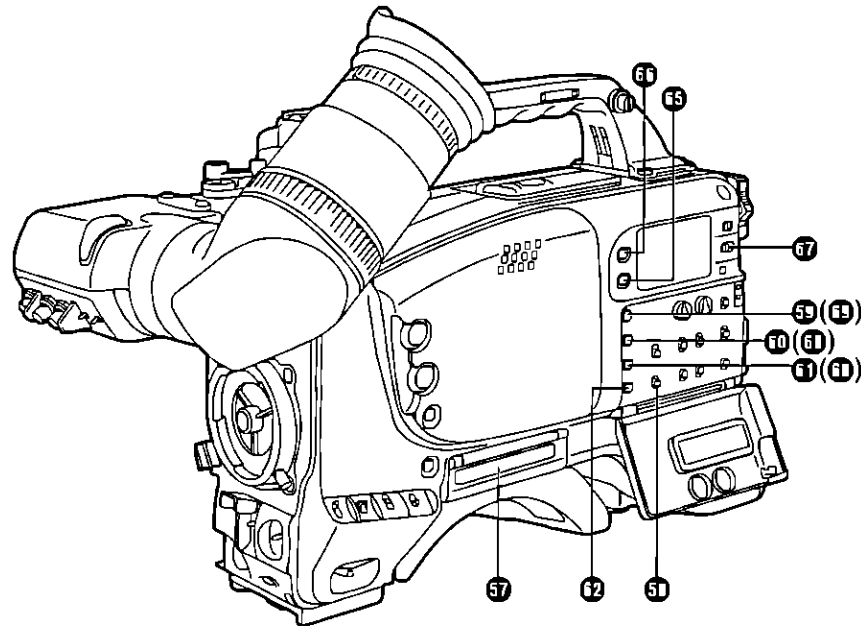

Menu Operation Section

- ⑤⑦ **Setup card insertion slot**
The optional setup cards are inserted into this slot
- ⑤⑧ **MENU SET/OFF switch**
This displays the setting menu on the viewfinder screen
SET The page on which the previous setting menu operations were completed appears on the viewfinder screen (When the menu is used for the first time, the first of the pages which can be displayed appears)
OFF The setting menu is not displayed on the viewfinder screen
- ⑤⑨ **SHIFT/ITEM button**
Each time this button is pressed, the cursor moves on the setting menu page now displayed
Use it when selecting items
<Note>
This switch functions differently depending on the operation item. Check the function by operating the menu item by item
- ⑤⑩ **UP button**
This is used to increment the setting of the item selected on the setting menu by 1 level each time it is pressed or to switch the setting between ON and OFF
- ⑤⑪ **DOWN button**
This is used to decrement the setting of the item selected on the setting menu by 1 level each time it is pressed or to switch the setting between ON and OFF
- ⑤⑫ **PAGE button**
This is used to select the setting menu page

Time Code-Related Section (1)

- ⑤⑬ **GENLOCK IN connector (BNC)**
The reference signal is supplied to this connector for genlocking with the camera section

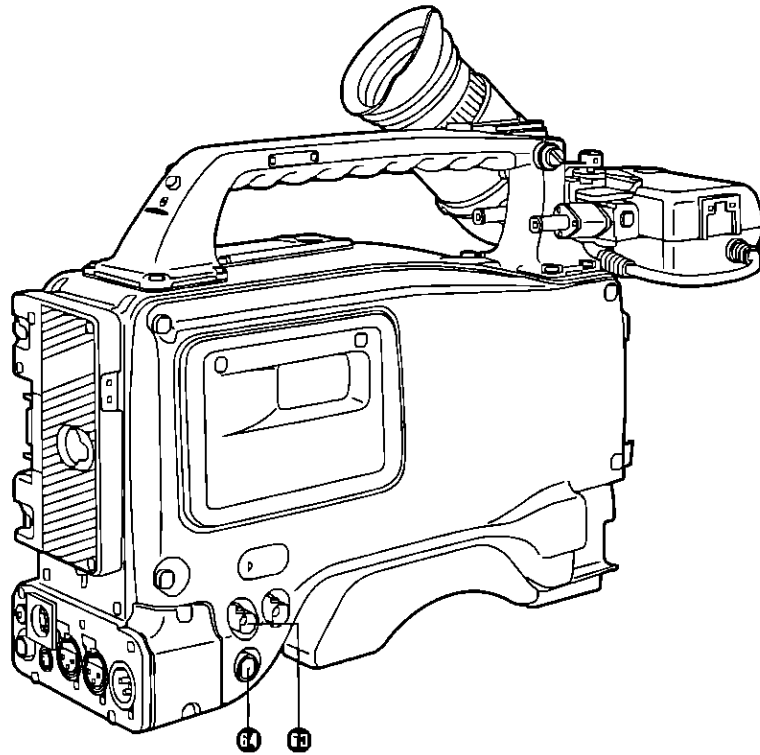

64 Multi (TC IN/OUT, AUDIO OUT CH1/CH2) connector

TC IN side

The time code serving as the reference is input when the time code is locked to an external source

TC OUT side

Connect this to the time code TC IN connector on the external VTR when locking the external VTR's time code to this unit's time code

AUDIO OUT CH1/CH2 side

This is the audio output connector. The audio signal is output at -20 dB (0 dB= 0.775 V), unbalanced

Time Code-Related Section (2)

65 HOLD button

The time data appearing on the counter display at the instant when this button is pressed is held. (The time code generator will still continue to run.) When the button is pressed again, the hold status is released. Use the button to ascertain the time at which a particular scene was shot, for example.

66 RESET button

This resets the time data or user's bit data on the counter display to "00 00 00 00" or "00 00 00 00", respectively.

67 DISPLAY switch

The time code, CTL or user's bit is made to appear on the counter display depending on the setting positions of this switch and the TCG switch **68**.

UB The user's bit is displayed

TC The time code is displayed

CTL CTL is displayed

68 UP button, DOWN button

When setting the time code or user's bit, these buttons increment or decrement by 1 the figure of the digit made to flash by the SHIFT/ITEM button **69**.

69 SHIFT/ITEM (digit advance) button

When setting the time code or user's bit, this button is used to cause the digit which is to be set to flash.

Controls and Their Functions

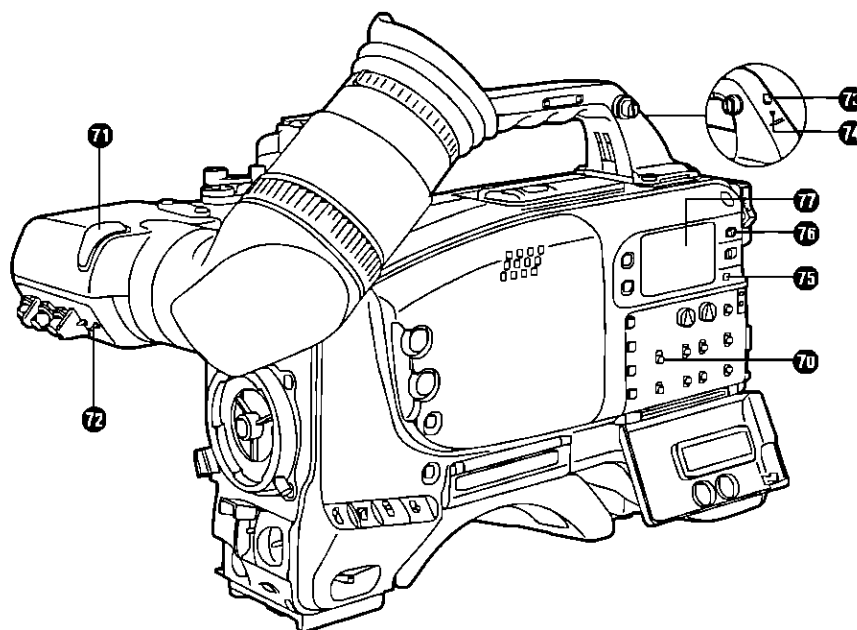

70 TCG (time code selector) switch

This is used to set the running mode of the internal time code generator

F-RUN This position is used when the time code is to be advanced continuously regardless of the VTR's operation

Set to this position when aligning the time code with the actual time or locking the time code to an external source

SET This position is used for setting the time code or user's bit

R-RUN This position is used when the time code is to be advanced only while recording is in progress. The time code will be recorded continuously on a tape with a succession of unedited shots

Warning/Status Display Section

71 Tally lamp

This is activated when the TALLY switch **72** is at HIGH or LOW, and it lights during recording by the VTR section. It flashes in the same way as the REC lamp inside the viewfinder to warn the operator. The brightness when lighted can be selected using the TALLY switch (HIGH or LOW)

72 TALLY switch

This controls the tally lamp **71**

HIGH The tally lamp is made brighter

OFF The tally lamp is extinguished

LOW The tally lamp is made darker

75 Back tally lamp

This functions in the same way as the tally lamp **71** when the back tally switch **76** is set to ON

76 Back tally switch

This controls the back tally lamp **75**

ON The back tally lamp operates

OFF The back tally lamp does not operate

77 WARNING lamp

This flashes or lights when trouble occurs in the VTR section

78 LIGHT switch

ON This illuminates the display window **79**

OFF This extinguishes the display window illumination

79 Display window

The warnings related to the VTR section, remaining battery level, sound level, time data, etc are displayed in this window

Power Supply

Power can be supplied to the unit using a battery pack or AC power supply

Using a battery pack

① Panasonic, ② Anton Bauer or ③ Sony batteries can be used for the battery pack

Before using a battery pack, be sure to charge it completely using a battery charger

■ See the Handling Instructions for the battery pack and battery charger for a detailed explanation of charging methods

Using an Anton Bauer Battery Pack

- 1 Mount the battery pack
Insert the battery pack in the direction of the arrow and then slide it into place

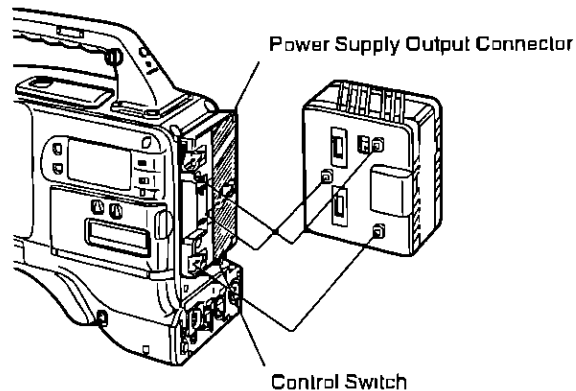

- 2 When detaching the battery, hold down the detachment lever of the battery holder and slide the battery pack in the direction of the arrow

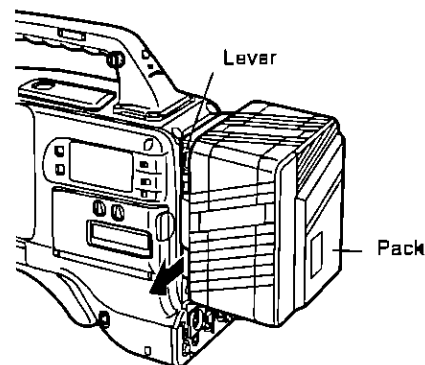

<Note>

The AJ-D700 supports the intelligent battery system and the ultra-light system. Automatic detection can be performed for intelligent batteries with a remaining battery level of 10% or more. At this time, the remaining battery level is displayed numerically (percentage display) inside the viewfinder. If the power is turned on with a remaining battery level of 10% or less, the voltage is displayed. Also, after intelligent battery detection, the remaining battery level display indicates the level for the intelligent battery even if power is supplied from an external source.

Power Supply

Using the Panasonic AU-BP402 Battery Pack

- 1 Detach the battery mounts

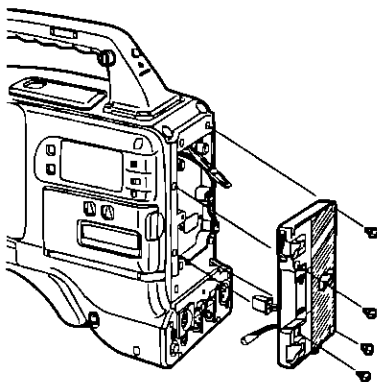

- 2 Connect the unit's connectors with the connectors of the AU-M402H battery case

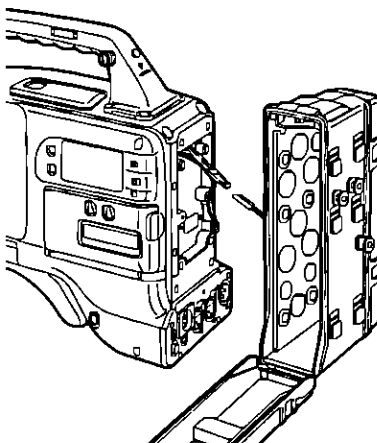

- 3 Mount the AU-M402H battery case
Open the battery case cover and lift up the rubber cap to expose the screw holes. Tighten the screws with a screwdriver and mount the case to the unit. Be sure to tighten the screws completely.

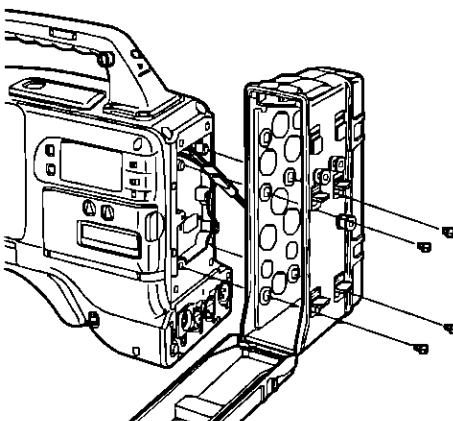

<Notes>

- Do not pull strongly on the rubber cap
- Take care not to catch the connection cord between the battery case and the main unit

-
- 4** Connect the battery pack plug to the connector inside the case and insert the battery pack

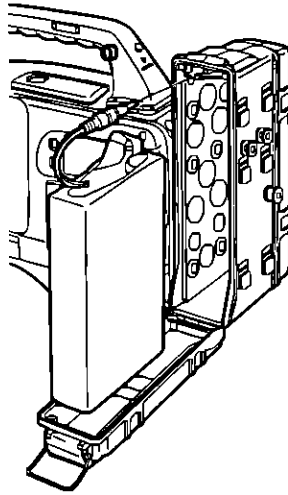

<Note>

The unit's power must be set to OFF before the plug is inserted or removed

Using a Sony Battery Pack

- 1** Remove the battery mounts
See page 24
- 2** Mount the accessory battery mounting connector

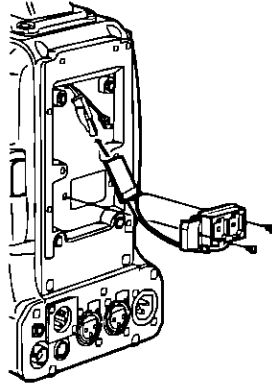

- 3** Mount the Sony battery holder
Mount the battery case with the cover detached first, and then mount the detached cover as shown in the figure
 - ① Tighten the mounting screws
 - ② Tighten the power supply contact screws
 - ③ Insert the top of the detached cover in the direction of the arrow
 - ④ Align the hole at the bottom (metal part) of the cover with the hole at the bottom of the case and mount the cover to the battery mounting connector with the screw of the battery holder

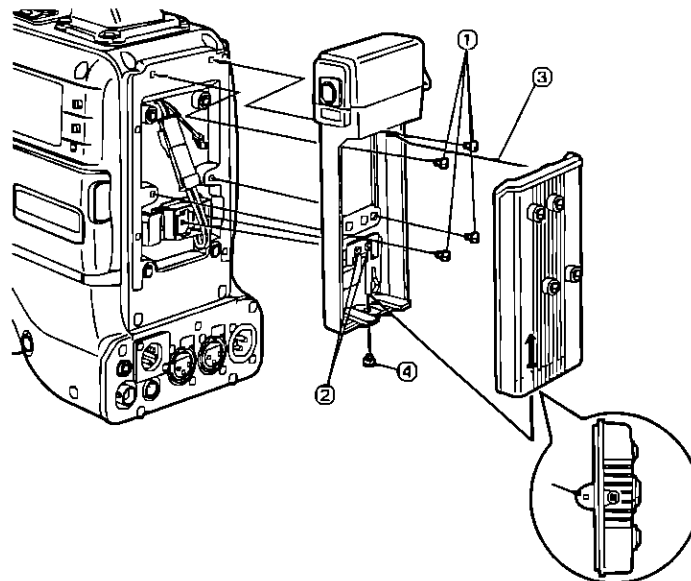

<Note>

Take care when attaching the battery holder that the wires are not pinched

Using the Sony BP-90 Battery Pack

- 1** Mount the accessory battery mounting connector
(See the preceding page)
- 2** Mount the BP-90 battery case
 - ① Tighten the mounting screws
 - ② Tighten the power supply contact screws
 - ③ Insert the top of the detached cover in the direction of the arrow
 - ④ Align the hole at the bottom (metal part) of the cover with the bottom of the case and mount the cover to the battery mounting connector with the screw

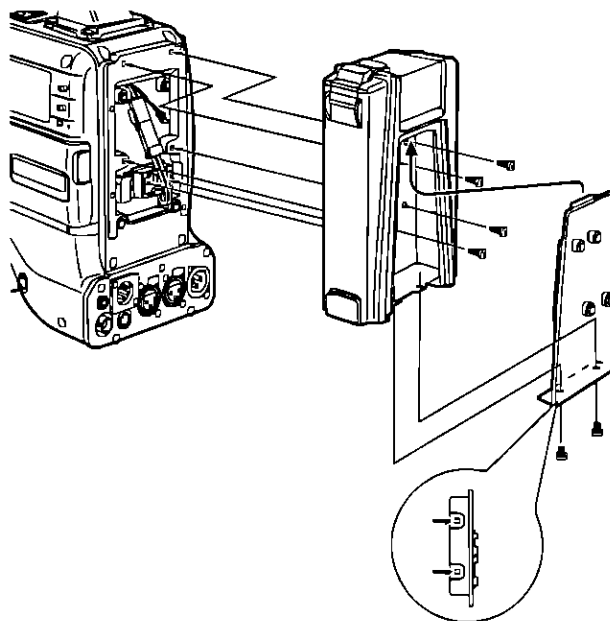

<Notes>

- The unit's power must be set to OFF before the plug is inserted or removed
- Take care when attaching the battery case that the wires are not pinched

Power Supply

Using an AC Power Supply (When using the AU-B110 AC Adaptor)

- 1 Connect the unit's EXT DC IN socket with the DC OUT connector of the AU-B110 AC adaptor

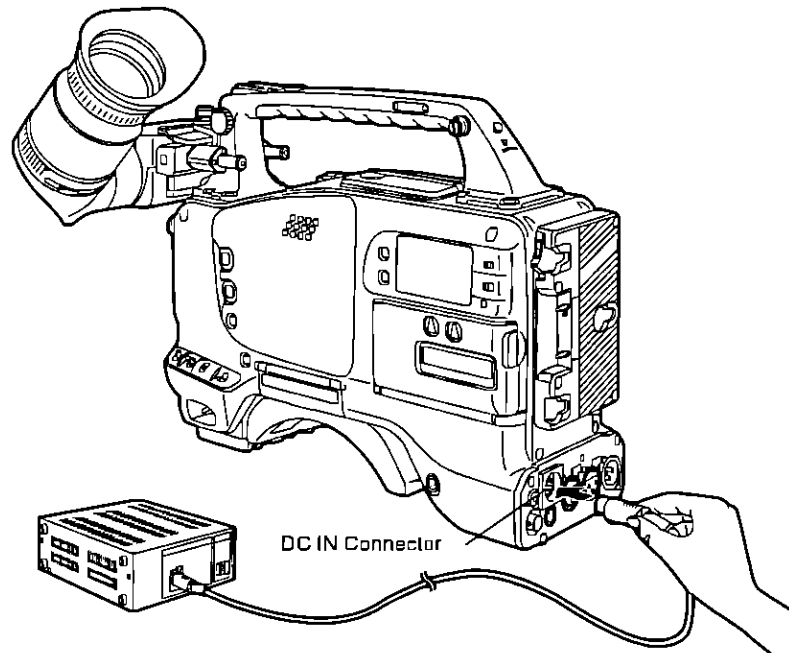

- 2 Set the AC adaptor's power to ON
- 3 Set the unit's power switch to ON

<Notes>

- When using an external power supply other than the AU-B110 AC adaptor, check the pin signal of the EXT DC IN socket
- When both a battery pack and AC adaptor are connected, power is supplied from the AC adaptor
- When using an AC adaptor, the AC adaptor's power must be set to ON before the unit's POWER switch is set to ON. If this sequence is reversed, the AC adaptor's output voltage will rise slowly and may cause the unit to malfunction

| Pin No | Signal |
|--------|--------|
| 1 | GND |
| 2, 3 | — |
| 4 | +12 V |

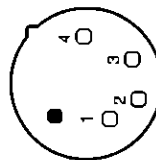

Mounting the Lens

- 1 Raise the lens clamping lever and remove the mount cap

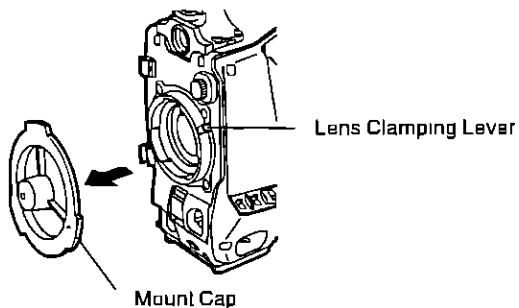

- 2 Align the indentation at the top center of the lens mount with the center mark of the lens and mount the lens

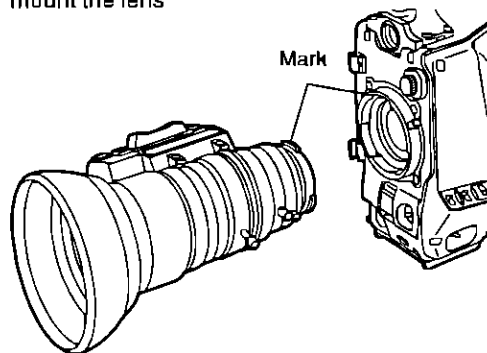

- 3 Lower the lens clamping lever and clamp the lens

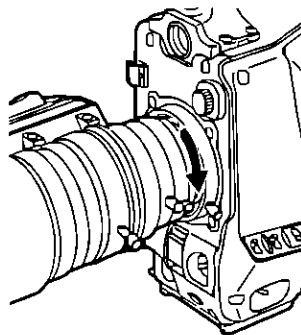

- 4 Press the cable into the cable clamp and connect it to the LENS connector

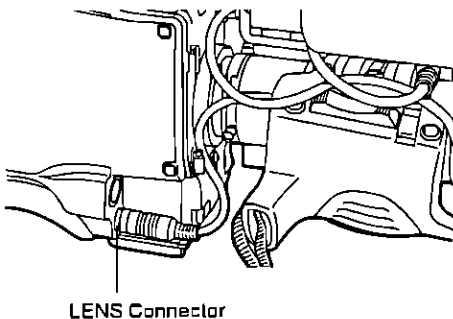

- See the Handling Instructions provided with the lens for lens handling

<Note>

The lens and camera adjustments listed below may be necessary depending on the lens to be mounted

- 1 Lens flanging adjustment
- 2 Lens auto iris adjustment
- 3 Lens white shading adjustment (with this unit)

Adjusting the Lens Flange

When images are not clearly focused at both the telephoto and wide-angle positions during zoom operations, adjust the flange back (the distance from the lens mounting surface to the image formation surface)

Once adjusted, the flange back does not need to be readjusted as long as the lens is not changed

Adjustment method

Check the position of each part of the lens which must be operated in order to adjust the flange back with the lens Handling Instructions

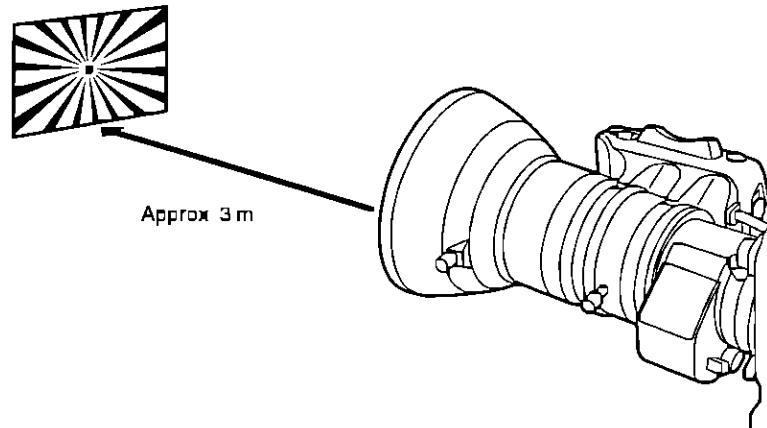

Adjusting the Flange Back

- 1** Set the lens iris to manual
 - 2** Open the iris. Position the flange back adjustment chart about 3 m from the lens and illuminate it so that an appropriate image output level is obtained
If the image level is too high, use the CC/ND filters or the shutter
 - 3** Loosen the Ff ring clamping screw
 - 4** Set the zoom ring to the telephoto position manually or by electric drive
 - 5** Shoot the flange back adjustment chart and turn the distance ring to bring the chart into focus
 - 6** Set the zoom ring to the wide-angle position
 - 7** Turn the Ff ring to bring the chart into focus
At this time, take care not to move the distance ring
 - 8** Repeat this operation four to seven times until the lens is in focus at both the telephoto and wide-angle positions
 - 9** Firmly tighten the Ff ring clamping screw
- Refer to the Operating Instructions of the lens

Adjusting the White Shading

The AJ-D700 is adjusted for the Fujinon S18×6.7 BERM4 (with extender) and S18×6.7 BRM4 (without extender) lenses when shipped from the factory. If a lens other than these two lenses is to be used, adjusting the white shading before shooting is recommended. In particular, be sure to adjust the white shading as indicated below when using a 1/2-inch camera lens without an extender (other than the S18×6.7 BRM4 noted above) or a 2/3-inch camera lens via an adaptor. The AJ-D700 is able to adjust the white shading for vertical coloring. (Vertical coloring refers to the condition where the top of the screen is green and the bottom is magenta or where these colors are reversed when a white paper is shot for the entire screen.)

White shading adjustment procedure

- 1** Mount a lens to the camera
Be sure to also connect the lens cable
- 2** Set the electronic shutter to OFF and the gain to L (0 dB)

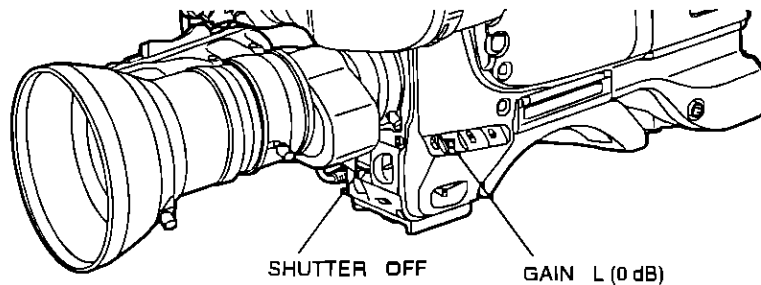

- 3** If the lens has an extender, remove the extender
- 4** Set the MENU SET/OFF switch from OFF to SET while holding down the SHIFT/ITEM and UP buttons to open the menu
Press the PAGE button until the VF OPERATION page appears
Set ZEBRA1 DETECT to 70, ZEBRA2 DETECT to 85 and ZEBRA2 to SPOT (Initial setting mode)
Return the MENU SET/OFF switch from SET to OFF to close the menu
Set the viewfinder's ZEBRA switch to ON

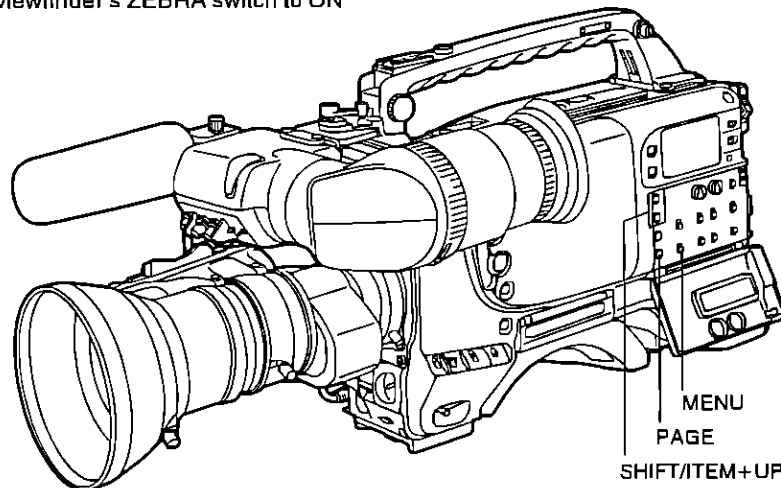

- 5** Shoot an evenly white paper
Flickering occurs easily when fluorescent or mercury lamps, etc are used for lighting. Therefore, use a light source which does not produce flickering such as sunlight or halogen lamps, etc.
- 6** Set the lens iris to manual and adjust the iris so that the ZEBRA pattern covers the entire screen. If the light strikes the subject in an uneven manner, the ZEBRA pattern will not cover a part of the screen. Therefore, adjust the position of the light source, etc as necessary.
Check that the lens iris is between F4 to F11. If the lens iris is not within this range, adjust the position of the light source, etc.
(Be sure to set the electronic shutter to OFF.)

-
- 7** Set the WHITE BAL selector switch to A or B execute AWB
Next, execute ABB and then execute AWB again

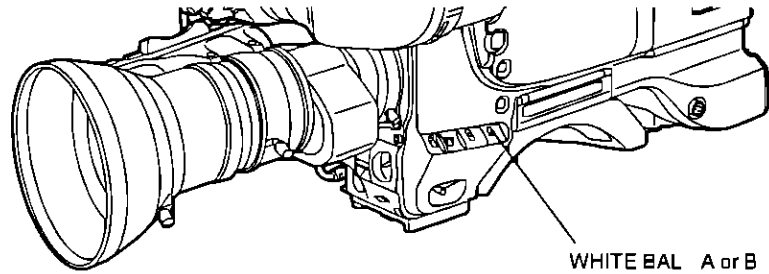

- 8** Repeat step 6

- 9** Set the MENU switch from OFF to SET while holding down the SHIFT/ITEM and UP buttons to open the menu
Press the PAGE button until the AUTO SHADING page appears
Press the SHIFT/ITEM button to move the arrow on the left to the WHITE position and then press the UP or DOWN button
ACTIVE appears on the viewfinder to indicate that white shading automatic adjustment is operating
Adjustment is completed when the ACTIVE display disappears
Return the MENU switch from SET to OFF to close the menu

- 10** When the lens to be used has an extender, insert an extender and repeat steps 6 to 9

This completes white shading adjustment

The adjustment value is stored in the non-volatile memory, so there is no need to readjust the white shading even if the power for the unit is turned off

<Notes>

- 1 The white shading can be adjusted for general lenses using the above method. However, this method may not apply for extremely special lenses.
- 2 When using a 2/3-inch camera lens, be sure to mount the lens using a conversion adaptor. These lenses cannot be mounted directly as their dimensions differ. Attempting to mount these lenses directly may damage the unit.
- 3 Vertical coloring may occur near the open position of the lens iris even after performing the above adjustments. However, this is characteristic of the optical system of the lens, and does not indicate a malfunction.

Adjusting the Viewfinder

- 1** Loosen the viewfinder forward-backward/left-right position clamp lever

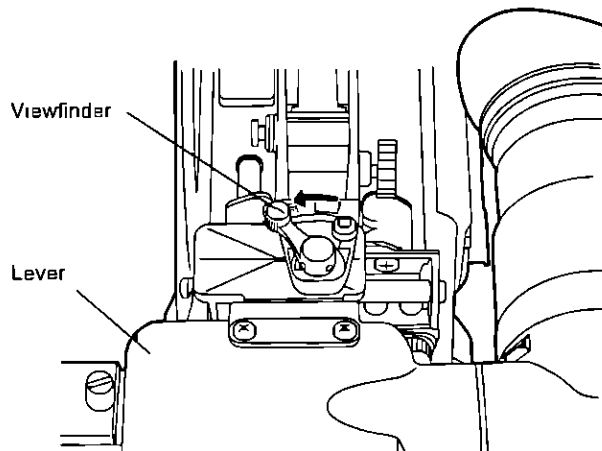

- 2** Adjust the position of the viewfinder in the forward-backward and left-right directions

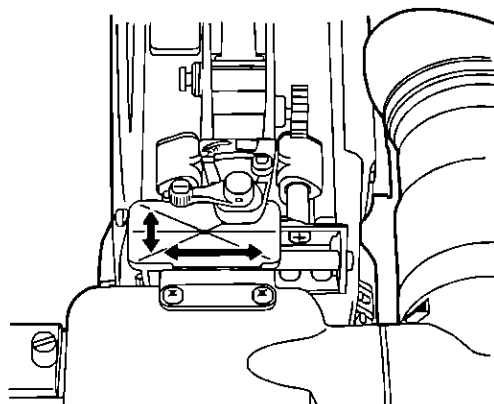

- 3** Tighten the viewfinder forward-backward/left-right position clamp lever to the locked position

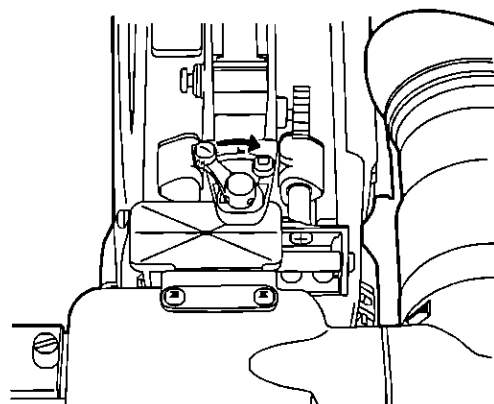

Adjusting the Viewfinder

Adjusting the Diopter and Screen

Adjusting the diopter

- 1 Set the POWER switch to ON. A picture will appear in the viewfinder.
- 2 Turn the diopter adjustment ring to adjust the diopter so that the viewfinder picture can be clearly seen.

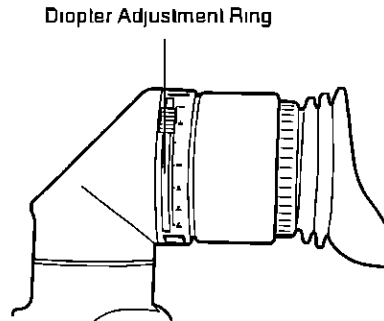

Adjusting the screen

Adjust the condition of the viewfinder screen

- Brightness** Adjust the BRIGHT control
- Contrast** Adjust the CONTRAST control
- Contour** Adjust the PEAKING control

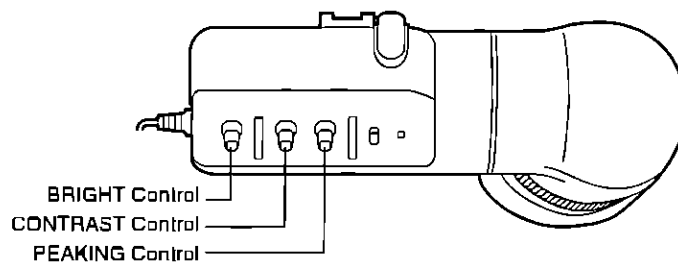

- 1 Set the POWER switch to ON.
- 2 Set the OUTPUT switch to CAM.
- 3 Turn the viewfinder BRIGHT and CONTRAST controls to adjust the picture brightness and contrast. Turning the PEAKING control makes the picture appear softer or sharper. A sharp picture facilitates focusing the lens.

Adjusting the Eyecup Position

Turn the eyecup forward-backward movement ring to adjust the position of the eyecup in the forward-backward direction.

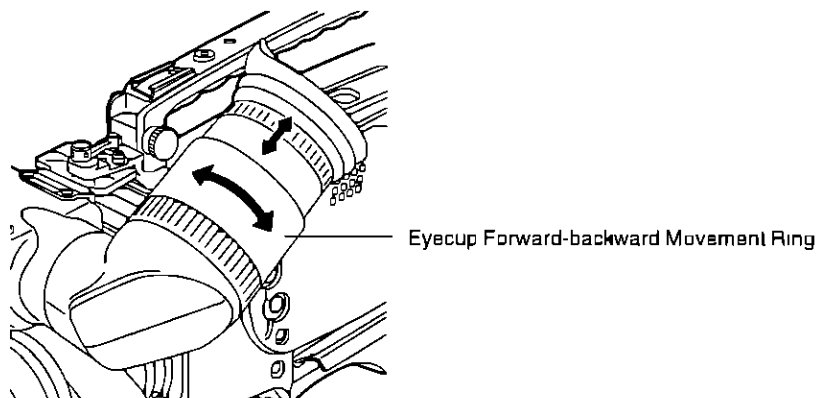

Detaching the Eyecup

Detaching the eyecup allows the entire screen to be seen clearly even when shooting with your eye removed from the viewfinder. This also facilitates the removal of dust which has adhered to the CRT screen and mirror.

<Note>

Absolutely do not wipe the mirror surface as it has been specially treated. Dust which has adhered to the mirror should be blown away with a blower, etc.

- 1 Press the lock button
- 2 Turn the lock ring as far as possible in the counter-clockwise direction and line up the alignment marks on the lock ring and viewfinder barrel

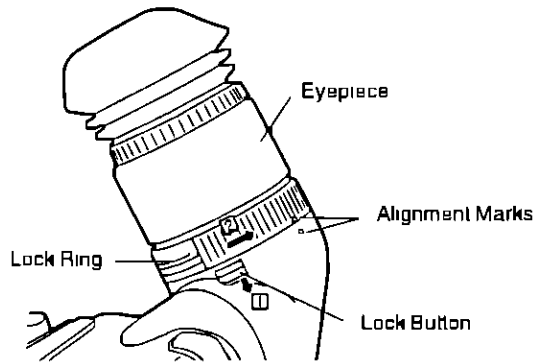

- 3 Detach the eyecup



Remounting the eyecup

- 1 Line up the alignment marks on the lock ring and the viewfinder barrel
- 2 Line up the alignment mark at the tip of the eyepiece (see the illustration for step 2 above) with the alignment marks on the lock ring and the eyecup and insert the eyecup into the barrel
- 3 Turn the lock ring as far as possible in the clockwise direction and line up the lock ring's "LOCK" indication arrow with the alignment mark on the barrel of the viewfinder
- 4 The lock button latches with a clicking sound

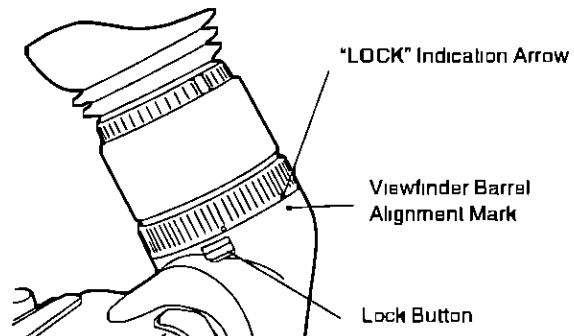

Adjusting the Viewfinder

Detaching the Viewfinder

- 1 Check that the POWER switch is set to OFF
- 2 Disconnect the plug from the viewfinder cable connector
<Note>
Use both hands to detach the viewfinder. The viewfinder may not detach smoothly with one hand, resulting in damage to the viewfinder.
- 3 Loosen the viewfinder stopper screw and detach the viewfinder by pulling it straight up

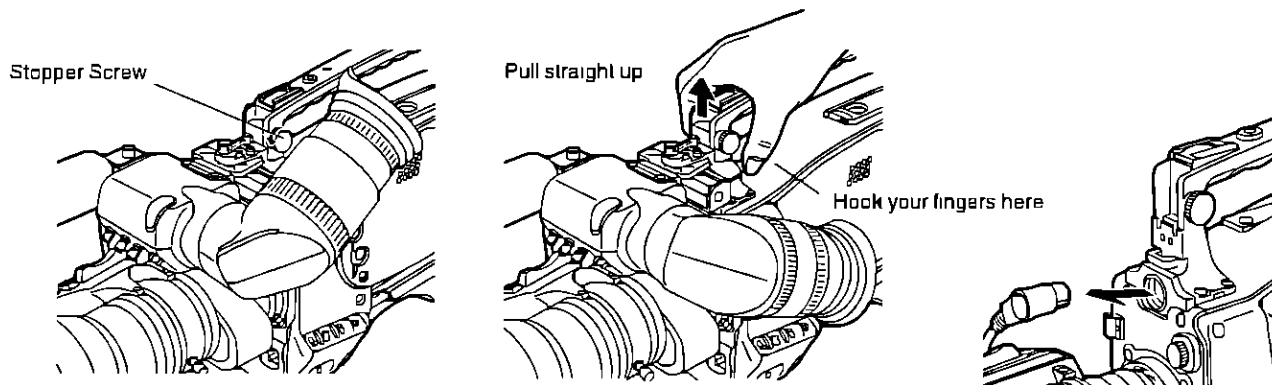

Mounting the Viewfinder

- 1 Press down the viewfinder
- 2 Tighten the viewfinder stopper screw firmly
- 3 Connect the plug to the viewfinder connector and secure the viewfinder cable with the clamp
<Note>
Insert the plug firmly when connecting it to the viewfinder connector

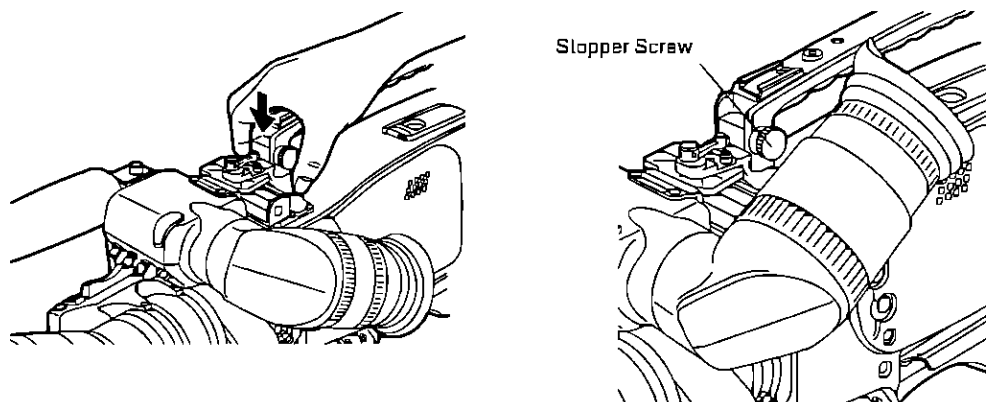

Audio Input Preparations

Using the Microphone Mounted to the Main Unit

Using the AJ-MC700P microphone kit (option) or the AJ-MH700P microphone holder (option) allows a microphone to be mounted to the main unit

▪ See the Handling Instructions for the microphone holder

When using the AJ-MC700P microphone kit (option) microphone mounted to the main unit

1 Mount the microphone holder

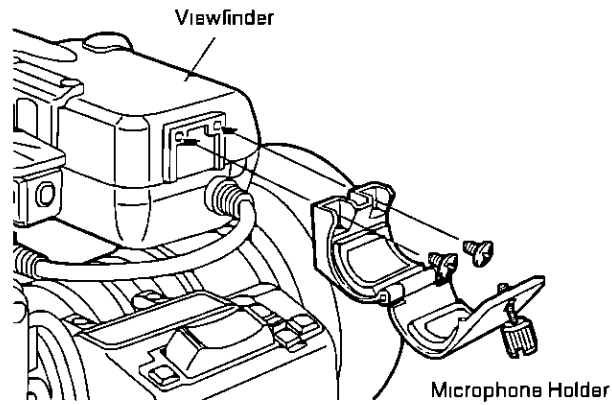

2 Mount the microphone

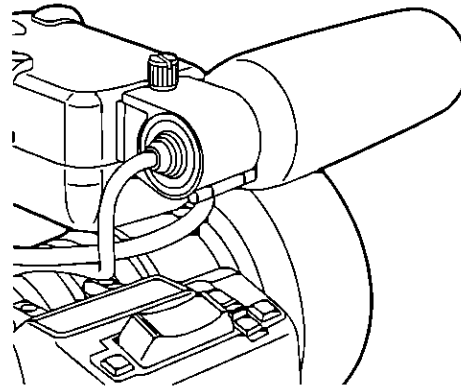

3 Connect the microphone connecting cable to the unit's MIC IN jack

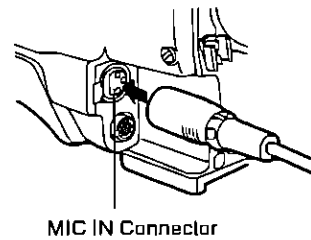

Audio Input Preparations

Mounting the AJ-MH700P microphone holder (option)

- 1 Remove the microphone holder mounting screws

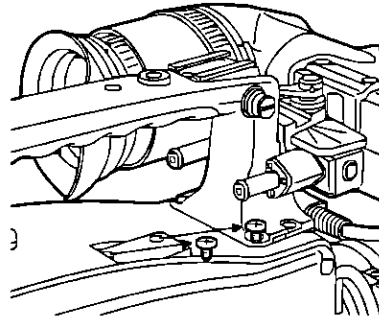

- 2 Mount the AJ-MH700P microphone adaptor (option) to the main unit

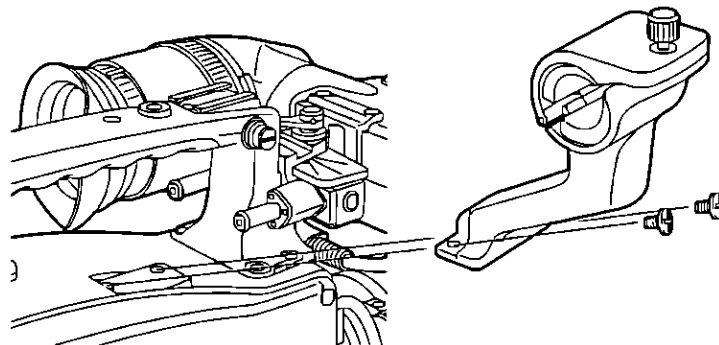

Mount the microphone adaptor using the accessory screws

- 3 Mount the microphone to the microphone holder and tighten the screws

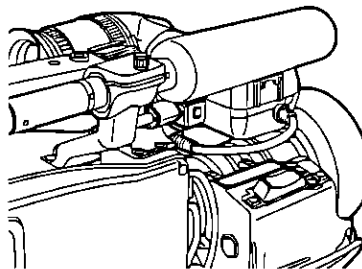

- 4 Connect the microphone connecting cable to the MIC IN jack

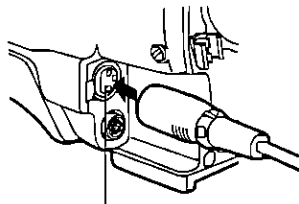

To the MIC IN Connector

- 5 Set the AUDIO IN switch to FRONT [MIC] in accordance with the audio channel to be recorded

Using the Microphone

When using the microphone not mounted to the main unit

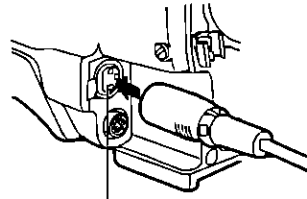

To the MIC IN Connector

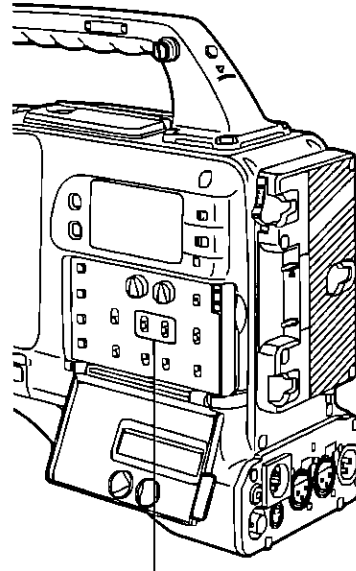

AUDIO IN switch Set the AUDIO IN switch for the audio channel you wish to record to FRONT [MIC]

<Note >

When extending the microphone, use a cable which supports the phantom power supply type of microphone

Audio Input Preparations

When Using the Microphone not Mounted to the Main Unit

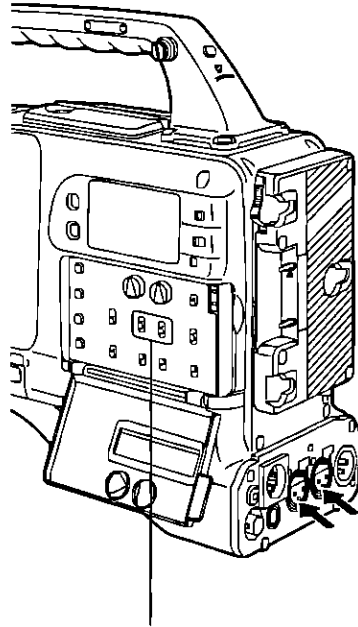

Up to two external microphones can be connected to the AUDIO IN CH1/CH2 Connectors
Phantom power supply type microphones can also be supported by a menu setting

AUDIO IN Switch Set the AUDIO IN Switches of the channels to which microphones are connected to REAR [MIC]

Mounting a Wireless Microphone

When using the Panasonic wireless microphone system, mount the WX-RA700 wireless receiver

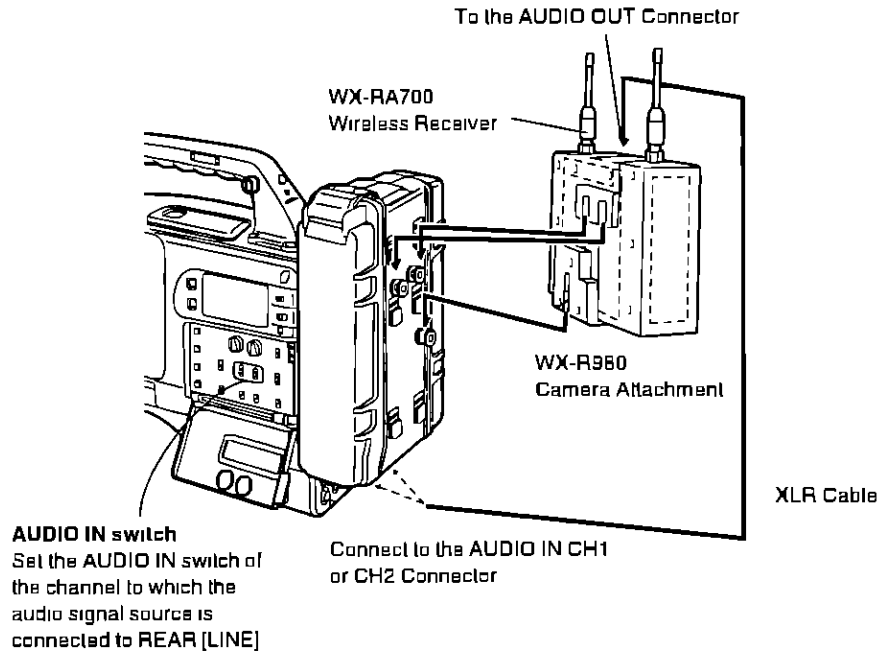

When detaching the wireless microphone, press up the lever on the bottom of the camera attachment (1) and detach the microphone in the upward direction (2)

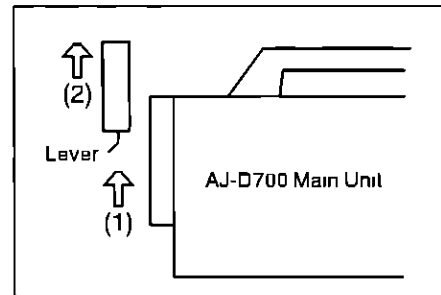

- See the Handling Instructions for the WX-RA700 wireless receiver for wireless receiver operations

Connecting an Audio Component

When using an audio component as the line input signal source, connect the audio component to the unit's AUDIO IN CH1/CH2 connectors

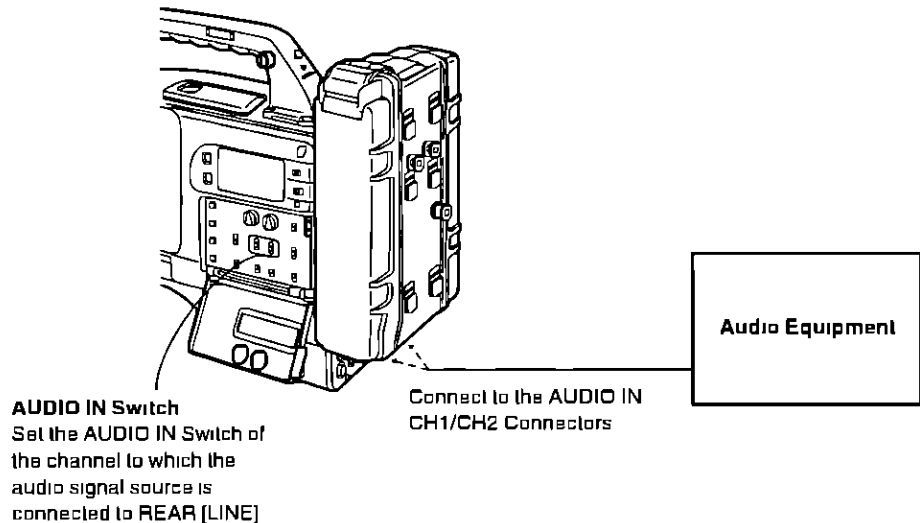

Mounting the Unit to a Tripod

When mounting the unit to a tripod, use an optional tripod attachment

- 1** Mount the tripod attachment to the tripod
Select the attachment hole in consideration of the unit's and tripod attachment's center of gravity. In addition, check that the diameter of the selected hole matches the diameter of the universal head's camera mounting screw.

Tripod Attachment

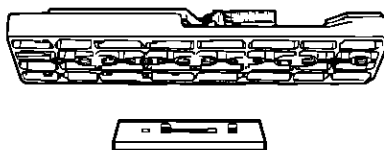

- 2** Mount the camera to the tripod attachment
Slide the unit forward along the grooves until a clicking sound is heard.

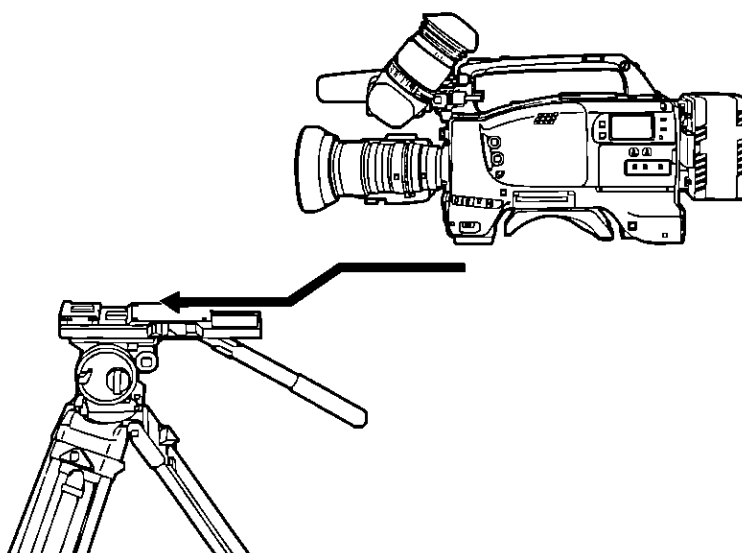

When detaching the tripod attachment

Hold down the red lever and move the black lever in the direction of the arrow.

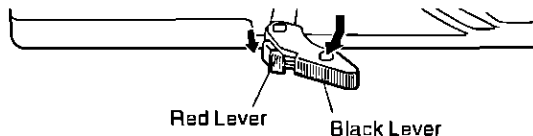

<Note >

When the tripod attachment pin does not return to its original position after the camera has been detached, hold down the red lever and move the black lever in the direction of the arrow again to return the pin to its original position.

Care should be taken as the camera cannot be mounted if the pin remains in the center.

Mounting the Shoulder Belt

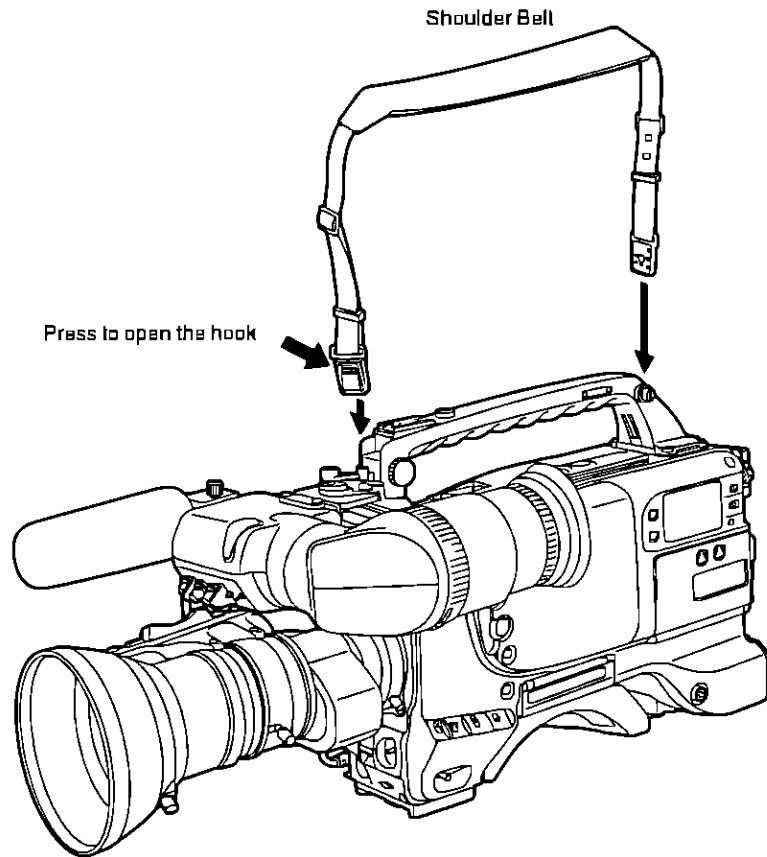

To remove the shoulder belt, open the hooks and then remove the belt

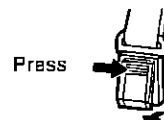

<Note>

When mounting and removing the shoulder belt, press on the top of the hooks to check that the belt is securely mounted

Adjusting the Shoulder Pad Position

The shoulder pad can be slid up to $\frac{2}{8}$ " in the forward-backward direction from the center position (the position when shipped from the factory) Adjust the shoulder pad position to facilitate operation of the unit

- 1** Loosen the two screws
- 2** Slide the pad in the forward-backward direction to select an appropriate position
- 3** Tighten the screws to clamp the pad

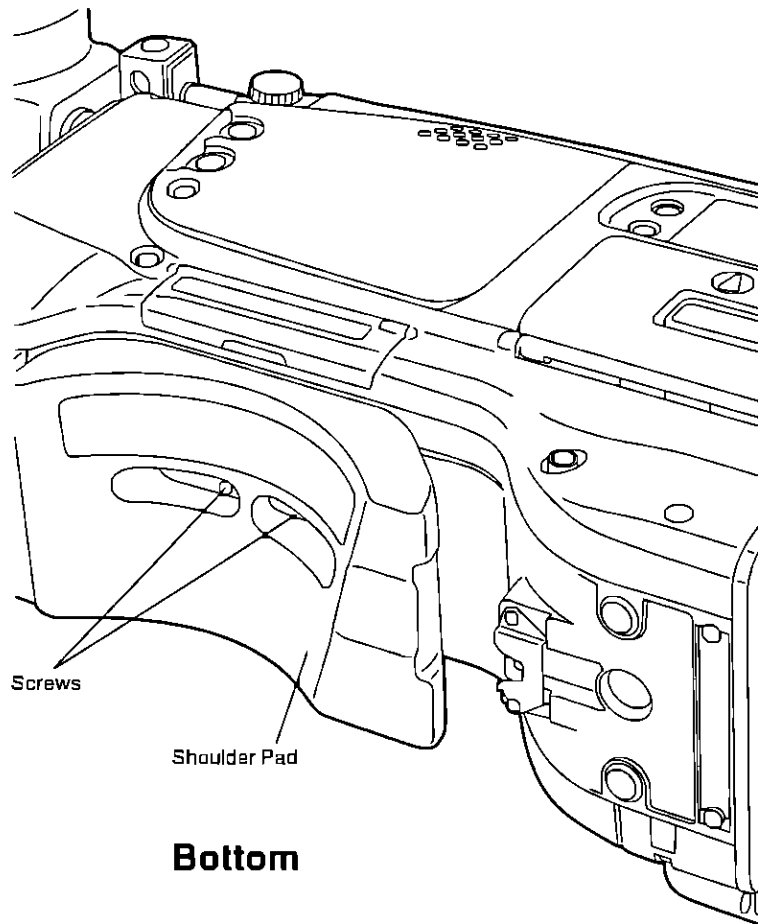

Attaching the Rain Cover

Attach the rain cover as shown in the figure below

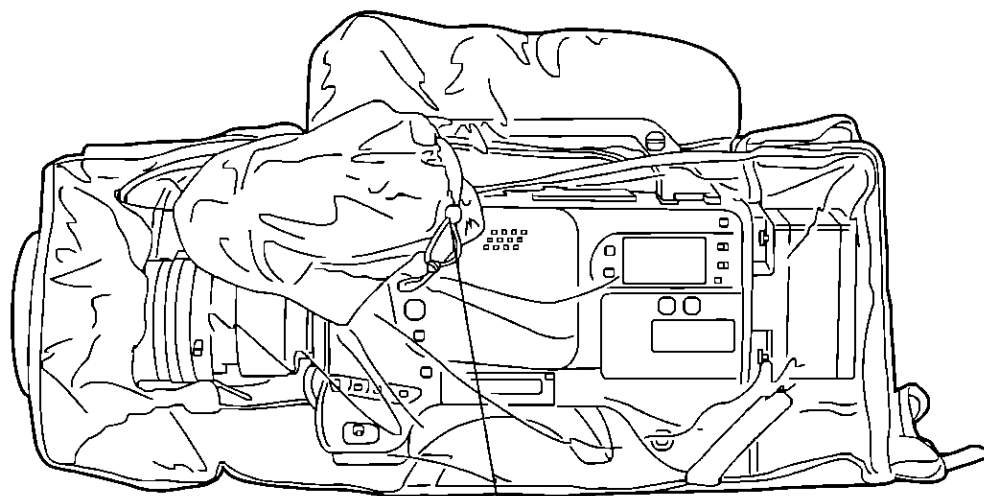

Tighten the Cord

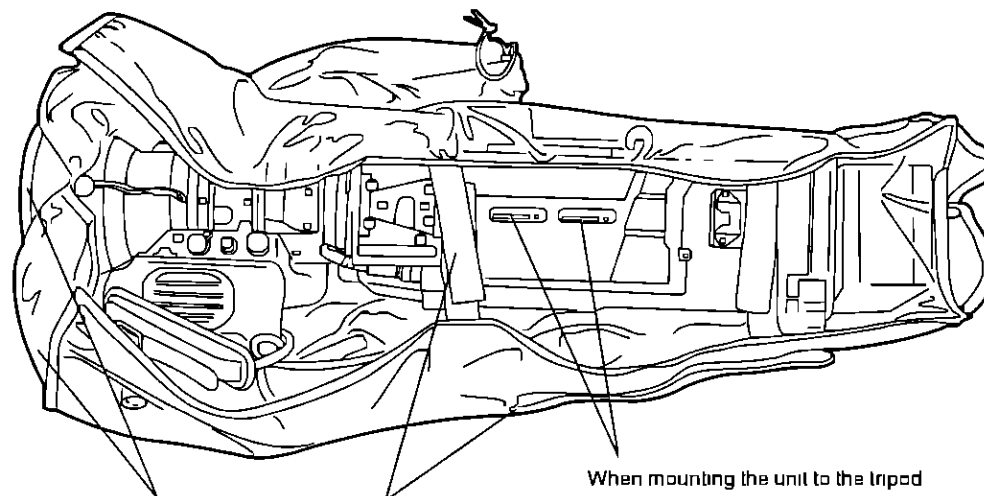

Secure the surface fastener

When mounting the unit to the tripod attachment, mount the unit using this hole

Connecting the AQ-EC1 Extension Control Unit (Option)

Connecting the AQ-EC1 extension control unit (option) allows a portion of the camera section functions to be operated by remote control

When the AQ-EC1 is connected and the POWER switches of the unit and AQ-EC1 are set to ON, the unit automatically enters remote control mode

The handling instructions included with the AQ-EC1 describe operations for when the AQ-EC1 is connected to an AQ series digital camera

When the AQ-EC1 is connected to the AJ-D700, some functions differ, and some features cannot be used

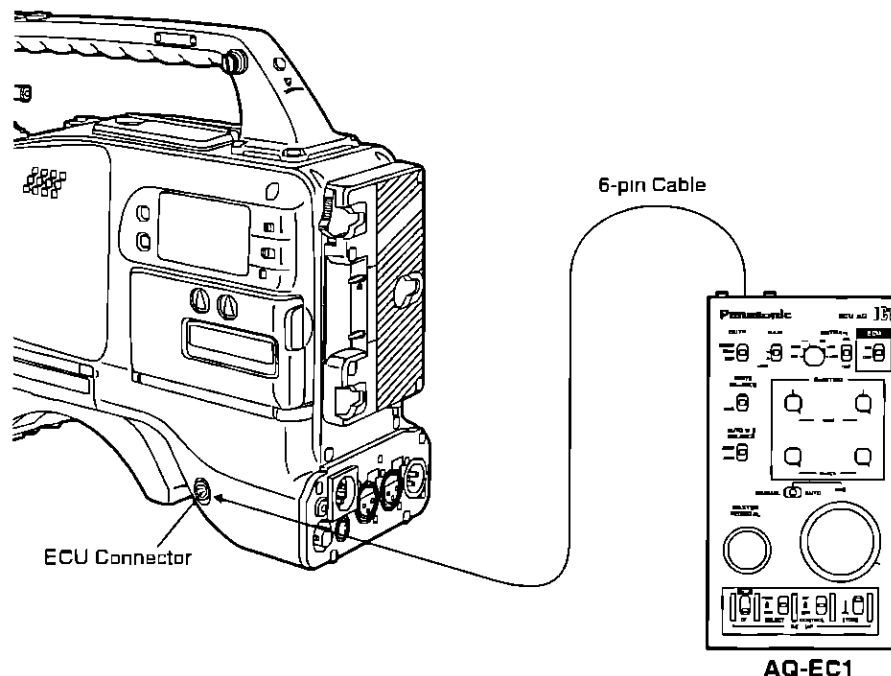

<Notes>

- The POWER switches of the unit and AQ-EC1 must be set to OFF before the 6-pin cable is connected or disconnected
- All adjustments and settings made using the switches and controls other than the menu setting section of the AQ-EC1 are erased when the unit's POWER switch is set to OFF. Also, adjustments and settings made using the AQ-EC1 cannot be written to setup cards. However, when the AQ-EC1 is connected again, these settings return to the AQ-EC1 settings (Menu contents set with the menu setting section are saved)

<Note>

The functions of the AQ-EC1 are limited as follows

- The STORE switch does not function
(If the menu settings are changed while the AQ-EC1 is connected to the AJ-D700, the new menu settings are saved automatically as soon as the changes are made)
Note that the AQ-EC1 gain switch displays -3, 0 and 9 correspond to L, M and H, and the OUTPUT switch settings CAMERA, TEST and BAR to CAM/AUTO KNEE ON, CAM/AUTO KNEE OFF and BAR for each main unit
- The Synchro scan and Super V modes cannot be used while the AQ-EC1 is connected to the unit
- The lens iris (IRIS) control of the AQ-EC1 is valid only when the lens iris AUTO/MANUAL selector is set to AUTO

Warning/Status Displays in the Viewfinder and Display Window

Displaying the Setting Menu Inside the Viewfinder

When the MENU SET/OFF switch is set to SET, the setting menu appears on the viewfinder screen. The setting menu is displayed in page units. The following table lists all pages contained in the setting menu as well as an outline of the functions for each page. The setting menu configuration can be changed according to the purpose.

Setting Menu Configuration

| Page No | Page name | Function outline | Reference |
|---------|------------------------|---|-----------------------------------|
| 58 | MARKER | Marker settings | Setting the Marker Displays |
| 56 | VF DISPLAY | Selection of viewfinder screen displays | Setting Display Items |
| 59 | CAMERA ID | Camera ID display settings | Setting the Camera ID Display |
| 72 | SHUTTER SPEED | Shutter speed/mode settings | Setting the Electronic Shutter |
| 73 | SYNCHRO SCAN | Synchro scan shutter speed settings | Setting the Electronic Shutter |
| 52 | ! LED | ! lamp display settings | Setting the ! Lamp Display |
| 81 | SET UP CARD | Setup card | Setup card operations |
| 106 | MAIN FUNCTION | Used function settings | — |
| 107–109 | FUNCTION 1/5 to 5/5 | Used function settings | Selecting Functions |
| 62 | TIME DATE | Time and date settings | Selecting Functions |
| 64 | SETTING LOW/MID/HIGH | Camera settings | Selecting Functions |
| 114–118 | LEVEL 1/6 to 6/6 | Camera settings | Recording Adjustments |
| 119 | VF OPERATION | Viewfinder operations | Viewfinder |
| 120 | LENS ADJ | Lens adjustments | Lens |
| 120–122 | MENU SELECT 1/3 to 3/3 | User menu ON/OFF settings | User Menu |
| 123 | AUTO SHADING | Automatic shading adjustments | Shading |
| 50 | DATA RESET | Resetting the setting menu | Returning to the default settings |
| 123 | DIAGNOSTIC | — | — |

See the corresponding pages for a detailed description of each page's functions.

<Note>

When connecting the AQ-EC1 extension control unit (option) and controlling the AJ-D700 externally, the engineer menu is always opened as the setting menu.

Warning/Status Displays in the Viewfinder and Display Window

Changing the setting menu configuration

The setting menu can be configured by selecting only the pages necessary for the application

Pages are selected using the MENU SELECT page of the engineer menu mode

When using the engineer menu, switch the unit to engineer mode as described below

The unit is switched to user mode by setting the MENU SET/OFF switch to "SET"

The unit is switched to engineer mode by holding down the SHIFT/ITEM and UP buttons simultaneously and setting the MENU SET/OFF switch to SET

The user and engineer modes differ as follows

User mode Only the selected pages the setting menu can be used. The data set on each page is written to the non-volatile memory, allowing it to be stored for extended periods of time

Engineer mode All pages contained in the setting menu can be used. In addition, the data set at each page is written to the non-volatile memory, allowing it to be stored for extended periods of time

After completing the adjustments and settings with engineer mode, configuring a menu consisting only of frequently used pages allows the necessary pages to be called quickly

Displaying the Setting Menu Inside the Viewfinder

Basic Setting Menu Operations

The setting menu is operated using the MENU SET/OFF switch and the SHIFT/ITEM, UP, DOWN and PAGE buttons

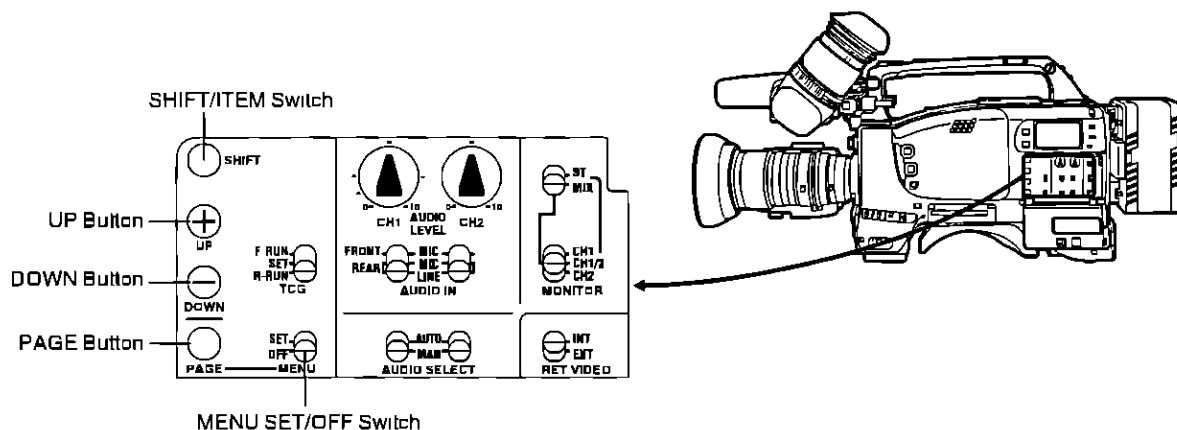

Displaying the setting menu

- 1 Set the MENU SET/OFF switch to SET
The status displays at the top and bottom of the viewfinder screen disappear, and the page on which the previous setting menu operations were completed appears
When the menu is used for the first time, the first of the selected pages appears

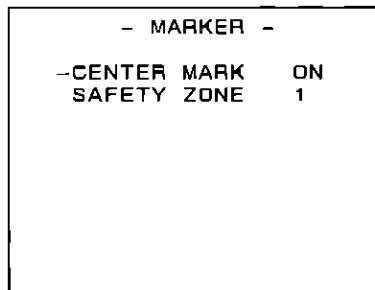

Changing the page

- 1 Press the PAGE button
The menu page changes each time the PAGE button is pressed

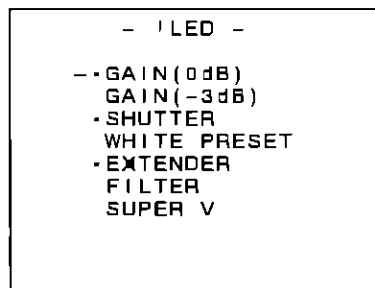

The page can also be changed using the UP and DOWN buttons as follows

- **PAGE+UP** The menu page is incremented continuously while the UP and PAGE buttons are held down
- **PAGE+DOWN** The menu page is decremented continuously while the DOWN and PAGE buttons are held down

Warning/Status Displays in the Viewfinder and Display Window

Selecting the desired item

- 1 Press the SHIFT/ITEM switch
Each time this button is pressed, the cursor (arrow) which indicates the selected item moves to the next item

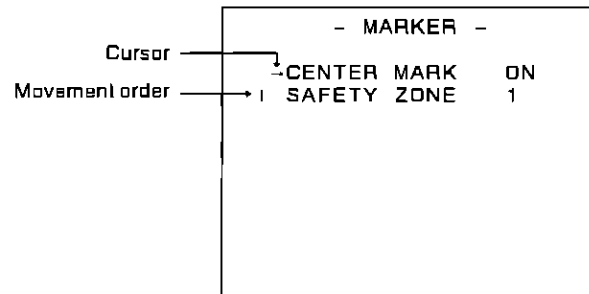

The item can also be selected using the UP and DOWN buttons as follows

Changing the settings

Press the UP button to increase the setting

- The setting is incremented by 1 level each time the UP button is pressed

Press the DOWN button to decrease the setting

- The setting is decremented by 1 level each time the DOWN button is pressed

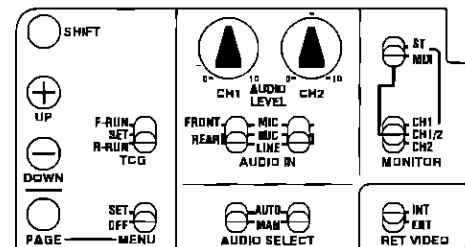

Changing the ON/OFF selection

The setting switches to ON or OFF each time the UP (or DOWN) button is pressed

Returning to the default settings

The unit can be returned to the default settings (the settings when shipped from the factory or the engineer mode settings) by pressing the UP (or DOWN) button at the DATA RESET page of engineer mode*

However, care should be taken as the flare and shading adjustment values cannot be returned to the default settings

Quitting the menu

Set the MENU SET/OFF switch to OFF

- The setting menu disappears from the viewfinder screen and the displays indicating the unit's current status appear at the top and bottom of the viewfinder screen

*Engineer mode

The menu for this mode is opened by holding down the SHIFT/ITEM and UP buttons simultaneously and then setting the MENU SET/OFF switch to the "SET" position

Lamp Displays Inside the Viewfinder

The viewfinder displays are as follows.

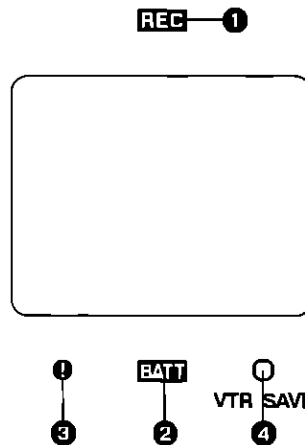

1 REC (recording) lamp

This lamp lights (red) during recording, and flashes when warnings are issued

• See “Warning System” (page 124) for a detailed description

2 BATT (battery) lamp

When the battery voltage has dropped, this lamp begins flashing several minutes before the unit can no longer be operated, and lights when the unit can no longer be operated

To prevent operation from being interrupted, exchange the battery quickly before the battery runs out

3 1 (irregular operation status warning) lamp

This lamp lights when the unit enters irregular operation status for any of the items set to ON at the 1 LED page of the setting menu. Applicable items are as follows

| Setting item | Setting contents |
|---------------------|---|
| Gain (0 dB) | The gain is set to a value other than 0 dB |
| Gain (-3 dB) | The gain is set to a value other than -3 dB |
| SHUTTER switch | The switch is set to ON |
| WHITE PRESET switch | The switch is set to PRESET |
| Lens extender | The lens extender is being used |
| Filter control | The control is set to a value other than 1 |
| SUPER V switch | The switch is set to ON |

• See “Setting the 1 Lamp Display” (next page) for selecting 1 lamp display items

4 VTR SAVE (VTR power saving) lamp

This lamp lights when the VTR SAVE/STBY switch is set to SAVE. It is not lighted during recording

<Note>

Regardless of the VTR SAVE/STBY switch, the unit automatically enters the SAVE state and the lamp lights either after two minutes when in the stopped state, or after the length of time set for the pause timer (the pause time) when in the paused state

Lamp Displays Inside the Viewfinder

Setting the ! Lamp Display

Items subject to ! lamp display are selected at the ! LED page of the setting menu (When shipped from the factory, the unit is set so that the ! LED page is not displayed) To operate the ! LED page, switch the unit to engineer mode or select the ! LED page at the MENU SELECT page

■ See "Setting Menu Configuration" (page 47) for engineer mode and selection of displayed pages

1 Set the MENU SET/OFF switch to SET
The setting status displays disappear from the viewfinder screen, and the page on which the previous setting menu operations were completed appears (When the menu is used for the first time, the first page appears)

2 Press the PAGE button until the ! LED page shown below appears (This operation can also be performed using the PAGE+UP/DOWN buttons)

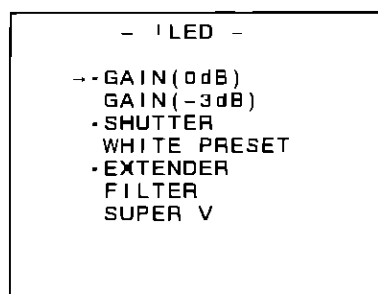

<Note>

- ON
OFF

- | | |
|-------------------|--|
| → - GAIN (0 dB) | This selects whether or not the ! lamp lights when the gain is set to any value other than 0 dB |
| GAIN (-3 dB) | This selects whether or not the ! lamp lights when the gain is set to any value other than -3 dB |
| - SHUTTER | This selects whether or not the ! lamp lights when the SHUTTER switch is set to ON |
| WHITE PRESET | This selects whether or not the ! lamp lights when the white balance memory channel is PRST |
| - EXTENDER | This selects whether or not the ! lamp lights when the lens is in EXTENDER mode |
| FILTER | This selects whether or not the ! lamp lights when the filter is set to any value other than 3200K |
| SUPER V | This selects whether or not the ! lamp lights when SUPER V is set to ON |

3 Repeatedly press the SHIFT/ITEM button to move the cursor to the position of the desired item

4 Press the UP and DOWN buttons to choose ! lamp lighted/not lighted for the selected item
To select ON Press the UP button An asterix (-) appears to the left of the item name
To select OFF Press the DOWN button A period (.) appears to the left of the item name

Repeat steps 3 and 4 to continue making ON/OFF settings for other items

5 When menu operations have been completed, set the MENU SET/OFF switch to OFF
The setting menu disappears from the viewfinder screen and the displays indicating the unit's current status appear at the top and bottom of the viewfinder screen

Status Displays Inside the Viewfinder Screen

In addition to images, messages indicating the unit's settings and operating status appear on the viewfinder screen. The center marker and safety zone marker, etc. are also displayed. When the MENU SET/OFF switch is set to OFF, items set to SET at the VF DISPLAY page of the setting menu and using related switches appear at the top and bottom of the screen.

Messages informing of the setting contents or of the adjustment course or results can also be displayed for approximately 3 seconds when settings are changed, during the course of adjustments, or after adjustments have been completed.

■ See "Selecting Display Items" (page 56) for selecting display items, "Display Mode and Setting Change Message" (page 57) for the setting change message, and "Setting the Marker Displays" (page 58) for the marker displays.

The display positions of all items which can be displayed are shown in the figure below.

- 1 Extender display
- 2 Shutter speed/mode display
- 3 Remaining tape length display
- 4 Remaining battery level display
- 5 Filter display
- 6 White balance memory display
- 7 Gain value display
- 8 Audio level display
- 9 Iris value display
- 10 Warning display
- 11 Safety zone marker
- 12 Center marker
- 13 Super iris ON display

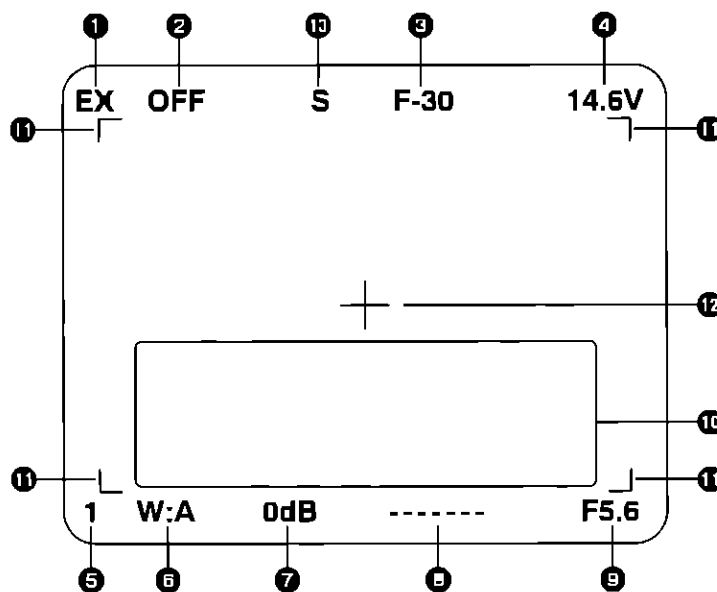

Status Displays Inside the Viewfinder Screen

1 Extender display

This is displayed when the lens extender is being used

2 Shutter speed/mode display

This displays the shutter speed or shutter mode setting

OFF The shutter is not used

1/100, 1/120, 1/250, 1/500, 1/1000, 1/2000

Shutter speeds (seconds) during standard mode

1/30 4–1/250 (SYNCHRO SCAN)

Synchro scan mode is selected

SUPER V

High vertical resolution mode is selected

3 Remaining tape length display

This indicates the remaining tape length (minutes) for the VTR during recording

Remaining tape length display

| Display | Remaining tape length |
|---------|-----------------------|
| F-30 | Full to 30 minutes |
| 30-25 | 30 to 25 minutes |
| 25-20 | 25 to 20 minutes |
| 20-15 | 20 to 15 minutes |
| 15-10 | 15 to 10 minutes |
| 10-5 | 10 to 5 minutes |
| 5-0 | 5 to 0 minutes |

The "5-0" display flashes when there is less than 3 minutes of tape remaining

4 Remaining battery level display

When an Anton Bauer Digital Magnum Series battery is used to supply power to the unit, the remaining battery level is displayed numerically (%)

5 Filter display

This displays the type of filter selected

6 White balance memory display

This displays the selected white balance automatic adjustment memory

A The WHITE BAL switch is set to A

B The WHITE BAL switch is set to B

P The WHITE BAL switch is set to PRST

7 Gain value display

This displays the image amplifier gain setting (dB) set by the GAIN switch

<Note>

When using an Anton Bauer Digital Magnum Series battery, the remaining battery level display continues to display the level for the Anton Bauer battery even if power supply is switched to an external power source near the end of the battery's power. However, note that the unit operates according to the external power source

8 Audio level display

This displays the audio CH1 level

During sine wave input, the audio level display corresponds roughly to the VTR level meter display as follows

| | | | | | | | |
|-------------------------------|-----|-----|-----|-----|-----|----|---|
| Audio Channel 1 Level Display | | | | | | | |
| VTR Level Meter | -40 | -30 | -25 | -20 | -15 | -8 | 0 |

9 Iris value display

This displays the approximate iris setting (F number)

10 Warning display

This displays the black balance, white balance, auto knee function, super iris, super high gain and other warning displays

11 Safety zone marker

This indicates the 80% or 90% (setting when shipped from the factory) range for the viewfinder screen area. The screen area percentage is selected at the MARKER page of the setting menu

- See "Setting the Marker Displays" (page 58) for a detailed description

12 Center marker

This indicates the center of the viewfinder screen. This marker is displayed when set to ON at the MARKER page of the setting menu

13 Super iris ON display

This indicates that the super iris is ON

1) Iris value display

The iris value is displayed when using a lens with the iris value display function

Status Displays Inside the Viewfinder Screen

Selecting Display Items

The items to be displayed on the viewfinder screen can be selected by switching the display ON/OFF setting independently for each item at the VF DISPLAY page. The items which can be selected are as follows.

- Display mode (See "Display Mode and Setting Change/Adjustment Course Message")
- Extender display
- Shutter speed/mode display
- Remaining tape length display
- Remaining battery level display
- Filter display
- White balance memory display
- Gain value display
- Level meter display
- Iris value/super iris ON status display
- Camera ID display

■ The camera ID is displayed when recording the color bar according to the OUTPUT/AUTO KNEE switch setting. See "Setting the Camera ID" (page 59) for a detailed description.

Select the items to be displayed on the viewfinder screen.

- 1** Set the MENU SET/OFF switch to SET.
The page on which the previous setting menu operations were completed appears on the viewfinder screen. (When the menu is used for the first time, the first page appears.)
- 2** Press the PAGE button until the VF DISPLAY page shown below appears.
(This operation can also be performed using the PAGE+UP/DOWN function.)

| | | |
|---|---|----------------|
| Display mode | — | - VF DISPLAY - |
| Extender display | — | -DISP MODE 3 |
| Shutter speed/mode display | — | EXTENDER ON |
| Remaining tape length display | — | SHUTTER ON |
| Remaining battery level display | — | TAPE ON |
| Filter display | — | BATTERY ON |
| White balance memory display | — | FILTER ON |
| Gain value display | — | WHITE ON |
| Level meter display | — | GAIN ON |
| Iris value/super iris ON status display | — | LEVEL METER ON |
| Camera ID display | — | IRIS IRIS |
| | | CAMERA ID ON |

- 3** Press the SHIFT/ITEM button to move the cursor to the position of the desired item.
- 4** Press the UP and DOWN buttons to choose whether to display (ON) or not display (OFF) the selected item on the viewfinder screen.
The setting switches to ON or OFF each time the UP (or DOWN) button is pressed.
Repeat steps 3 and 4 when setting display ON/OFF for other items.
- 5** When menu operations have been completed, set the MENU SET/OFF switch to OFF.
The setting menu disappears from the viewfinder screen and the displays indicating the settings of the selected items appear.

Display Mode and Setting Change Message

Messages informing of the contents of changed settings and adjustment results can be limited to part of the displayed items or not displayed for all items

The conditions under which messages are displayed and the corresponding display modes are shown in the table below

Setting change/adjustment results messages and display modes

| Conditions under which messages are displayed | Message | Display mode setting | | |
|---|--|----------------------|---|---|
| | | 1 | 2 | 3 |
| When the filter selection is changed | ND n (n=1, 2, 3, 4) | × | × | ○ |
| When the gain setting is changed | GAIN n dB (n=-3, 0, 3, 6, 9, 12, 15, 18, 21, 24, 30) | × | × | ○ |
| When the WHITE BAL switch setting is changed | WHITE n (n=ACH, BCH, PRESET) | × | × | ○ |
| When the OUTPUT/AUTO KNEE switch is set to AUTO KNEE or OFF*) | AUTO KNEE ON (or OFF) | × | ○ | ○ |
| When the shutter speed/mode setting is changed | SS 1/100 (or 1/120, 1/250, 1/500, 1/1000, 1/2000, S SCAN, SUPER V) | × | ○ | ○ |
| When the white balance is adjusted (AWB) | Ex) AWB OK ▪ See "Adjusting the White Balance" (page 66) for a detailed description | × | ○ | ○ |
| When the black balance is adjusted (ABB) | Ex) ABB OK ▪ See "Adjusting the Black Balance" (page 69) for a detailed description | × | ○ | ○ |

○ Message displayed

× Message not displayed

*) The message is displayed for approximately 3 seconds immediately after the power for the unit is turned on

Status Displays Inside the Viewfinder Screen

Changing the Display Mode

The display mode setting appears on the VF DISPLAY page of the setting menu

- 1** Perform the operations in steps 1 to 3 of "Selecting Display Items" (page 56) to display the VF DISPLAY page of the setting menu on the viewfinder screen and align the cursor with the DISP MODE item
- 2** Press the UP or DOWN button to select the desired display mode
- 3** When menu operations have been completed, set the MENU SET/OFF switch to OFF

Setting the Marker Displays

Display ON/OFF switching for the center and safety zone markers and selection of 80% or 90% of the screen area as the safety marker range are performed at the MARKER page of the setting menu

- 1** Set the MENU SET/OFF switch to SET
The page on which the previous setting menu operations were completed appears on the viewfinder screen (When the menu is used for the first time, the first page appears)
- 2** Press the PAGE button until the MARKER page shown below appears
(This operation can also be performed using the PAGE+ UP/DOWN function)

| | | |
|--------------|----|--|
| - MARKER - | | |
| -CENTER MARK | ON | |
| SAFETY ZONE | 1 | |

- 3** Press the SHIFT/ITEM button to move the cursor to the position of the desired item
- 4** The setting switches to ON or OFF each time the UP (or DOWN) button is pressed
- 5** When menu operations have been completed, set the MENU SET/OFF switch to OFF
The setting menu disappears from the viewfinder screen and the displays indicating the unit's current status appear at the top and bottom of the viewfinder screen

Setting the Camera ID

The camera ID can be set at the CAMERA ID page of the setting menu

A camera ID of up to ten characters including English letters, symbols and spaces can be used

The camera ID is output when the OUTPUT/AUTO KNEE switch is set to BARS and the color bar signal is being recorded

<Note>

When the setting menu is displayed, the camera ID is not displayed even if the color bar signal is output

Setting the Camera ID

- 1** Set the MENU SET/OFF switch to SET
The page on which the previous setting menu operations were completed appears on the viewfinder screen (When the menu is used for the first time, the first page appears)

- 2** Press the PAGE button until the CAMERA ID page shown below appears
(This operation can also be performed using the PAGE+UP/DOWN function)

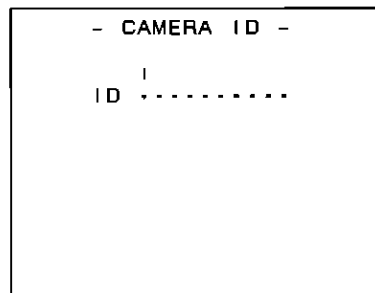

The cursor is moved to the right (max 10 spaces) by the SHIFT/ITEM button

English letters, symbols and space are switched by the UP and DOWN buttons

Camera ID

("*" indicates a space This indication is only used at this menu page)

- 3** Press the UP (or DOWN) button until the desired character appears
Each time the UP button is pressed, the character display changes in the order of English letters (A to Z)→numbers (0 to 9)→symbols [space, >, <,), (, ' ; - , _ , - , /, !] Pressing the DOWN button changes the character display in the reverse order
- 4** Press the SHIFT/ITEM button to advance the cursor to the next position and return to step 3 to set the characters
- 5** When menu operations have been completed, set the MENU SET/OFF switch to OFF
The setting menu disappears from the viewfinder screen and the displays indicating the unit's current status appear at the top and bottom of the viewfinder screen

Displays

Remaining Battery Level and Audio Level Displays

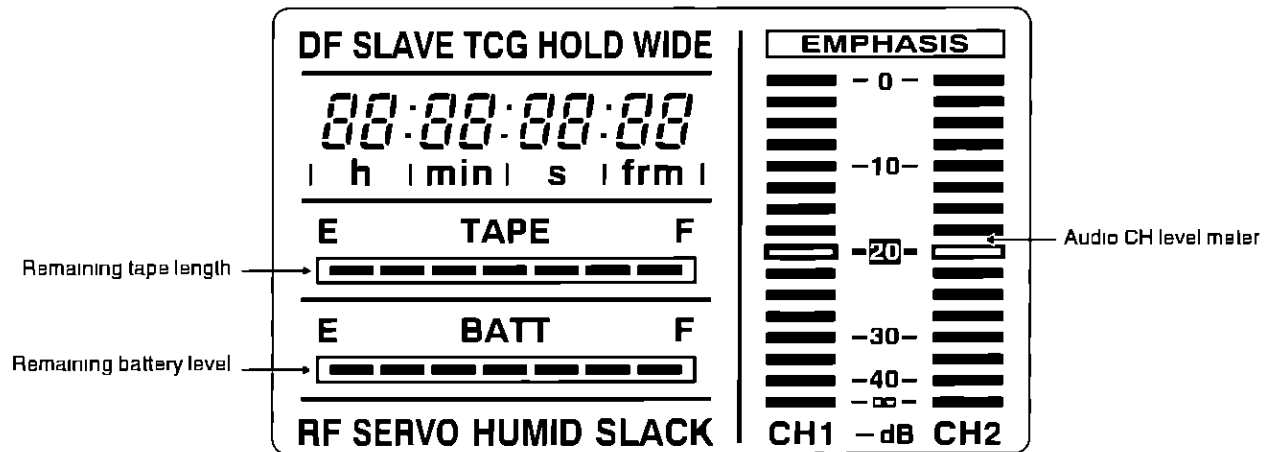

VTR Section Operation/Status-Related Displays

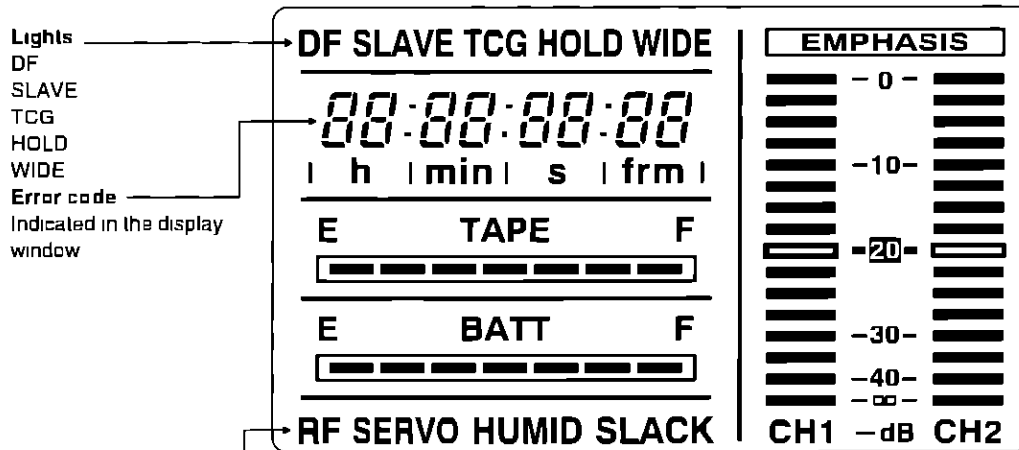

Warning display

- RF** Lights when video head clogging occurs
- SERVO** Lights when the servo is out of order
- HUMID** Lights when condensation occurs on the head drum
- SLACK** Lights when tape wind-up trouble occurs

• See "Warning System" (page 124) for a detailed description

Time Code-Related Displays

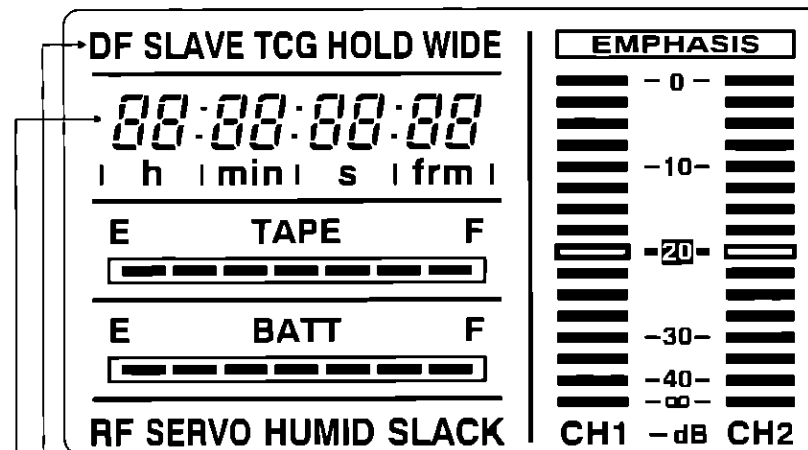

These lamps light to indicate the time code, CTL and real time displays

DF This lamp lights during drop frame mode

SLAVE This lamp lights when the time code is locked to an external source

HOLD This lamp lights when the time code generator is held (when the HOLD button is pressed)

Time counter display This displays the time code, CTL, user bit and real time

▪ See below for the relationship between displayed items and switch settings

Relationship between the TCG and DISPLAY switch setting positions and the time counter display

The item displayed in the time counter display is determined by the TCG switch and DISPLAY switch settings

Time code-related switch settings and display items

| TCG switch position | DISPLAY switch position | Displayed item |
|---------------------|-------------------------|----------------|
| SET | TC or CTL | Time code |
| | UB | User bit |
| F-RUN or R-RUN | CTL | CTL |
| | TC | Time code |
| | UB | User bit |

Adjusting the Time and Date

Adjustment and setup using the setting menu

- 1 Hold down the SHIFT/ITEM and UP buttons and set the MENU SET/OFF switch to SET. The unit switches to ENG mode.
The page on which the previous setting menu operations were completed appears on the viewfinder screen.
(When the menu is used for the first time, the first page appears.)
- 2 Press the PAGE button until the TIME/DATE page shown below appears.
(This operation can also be performed using the PAGE+UP/DOWN function.)

```
- TIME/DATE -  
  
--YEAR  95  
MONTH  01  
DAY    01  
HOUR   00  
MINUTE 00  
  
■TIME/DATE SET
```

- 3 Press the SHIFT/ITEM button to select the item to be changed.
- 4 Press the UP (or DOWN) button to change the setting value.
The number is incremented by +1 each time the UP button is pressed and decremented by -1 each time the DOWN button is pressed.

```
- TIME/DATE -  
  
YEAR   95  
MONTH  01  
DAY    01  
HOUR   00  
-MINUTE 00  
  
■TIME/DATE SET
```

- 5 When the settings have been completed, press the SHIFT/ITEM button to select TIME/DATE SET and then press the UP (or DOWN) button. The time starts from when the button is pressed.

```
■TIME/DATE SET
```

- 6 When menu operations have been completed, set the MENU SET/OFF switch to OFF.
The setting menu disappears from the viewfinder screen and the displays indicating the unit's current status appear at the top and bottom of the viewfinder screen.

<Note>

The seconds cannot be set and always start from 0 seconds.

Adjustments and Setup During Recording

Adjustments and Setup Using the Setting Menu

Adjustments and setup operations during recording are performed at the setting menu. Setting menu operations are basically performed according to the procedures described on page 49.

However, these procedures vary slightly according to the item. Items which can be adjusted or set up at the setting menu are as follows.

Adjustment/setup items at the setting menu

| Adjustment/setup item | Page name | Operation reference |
|---|---------------------------|---|
| Setting the gain selector value | SETTING (LOW/MID/HIGH) | Setting the Gain Selector Value, Setting the DTL and gamma, etc |
| Selecting the shutter speed/mode to be used | SHUTTER SPEED | Setting the Electronic Shutter |
| Setting the synchro scan mode shutter speed | SYNCHRO SCAN | Setting the Electronic Shutter |
| Selecting required functions | FUNCTION 1/5 to 5/5 | Selecting Functions |
| Shading adjustment | AUTO SHADING | Shading Adjustment |
| Setup card data operations | SET UP CARD | Setup Card Operations |

Adjustments and Setup During Recording

Setting the Gain Selector Value

When shooting in locations without sufficient brightness, bright images can be obtained by raising the gain. However, care should be taken as raising the gain also increases the noise.

The gain value for the image amplifier is selected by the GAIN switch. The gain values corresponding to the L, M and H positions of the GAIN switch are set at the MASTER GAIN page of the setting menu.

Setting the gain selector value

- 1** Set the MENU SET/OFF switch to SET
The page on which the previous setting menu operations were completed appears on the viewfinder screen.
(When the menu is used for the first time, the first page appears.)
- 2** Press the PAGE button to display the SETTING (LOW/MID/HIGH) page shown below.
(This operation can also be performed using the PAGE+UP/DOWN function.)

| - LOW SETTING - | |
|-----------------|------|
| -MASTER GAIN | 0 dB |
| H DTL LEVEL | 08 |
| V DTL LEVEL | 10 |
| DTL CORING | 03 |
| H DTL FREQ | 04 |
| DARK DTL | 00 |
| LEVEL DEPEND | 01 |
| MASTER GAMMA | 0.45 |
| BLACK STRETCH | OFF |
| MATRIX TABLE | A |

- 3** Press the SHIFT/ITEM button repeatedly to move the cursor to the MASTER GAIN position.
- 4** Press the UP or DOWN button to set the gain value.
The gain value can be set freely regardless of size from among -3, 0, 3, 6, 9, 12, 15, 18, 21, 24 and 30 dB.
When resetting the gain values to the settings when shipped from the factory (LOW=0 dB, MID=9 dB, HIGH=18 dB), select MENU INIT at the DATA RESET page of the setting menu and press the UP or DOWN button.
- 5** When menu operations have been completed, set the MENU SET/OFF switch to OFF.
The setting menu disappears from the viewfinder screen and the displays indicating the unit's current status appear at the top and bottom of the viewfinder screen.

Selecting Functions

VTR operation functions can be selected at the FUNCTION 3/5 page of the setting menu

Selecting the required functions

- 1** Set the MENU SET/OFF switch to SET
The page on which the previous setting menu operations were completed appears on the viewfinder screen
(When the menu is used for the first time, the first page appears)
- 2** Press the PAGE button to display the FUNCTION 3/5 page
(This operation can also be performed using the PAGE+UP/DOWN function)

| | |
|--------------------|---------|
| - FUNCTION 3 / 5 - | |
| -HUMID OPE | OFF |
| 2&P CONTROL | OFF |
| REC START | NORMAL |
| TC MODE | DF |
| UB MODE | USER |
| PAUSE TIMER | 30 |
| BATTERY SEL | NiCd-12 |
| TCG VF DISP | OFF |

- 3** Press the SHIFT/ITEM button to move the cursor to the position of the function to be changed
- 4** Press the UP (or DOWN) button to change the setting of the selected function
If settings for other functions are also to be changed, return to step 3
- 5** When menu operations have been completed, set the MENU SET/OFF switch to OFF
The setting menu disappears from the viewfinder screen and the displays indicating the unit's current status appear at the top and bottom of the viewfinder screen

Adjusting the White Balance/Black Balance

Adjusting the White Balance

Adjusting the white balance and black balance in the order of AWB (white balance adjustment)→ABB (black balance adjustment)→AWB will provide a better picture

Normally, the white balance and black balance do not need to be readjusted even if the power is turned off and then on again

However, the white balance must be readjusted when the lighting conditions change

If black balance and white balance adjustments are started when the display mode is set to "2" or "3", messages informing of the adjustment course and results will appear on the viewfinder screen. Set the display mode to "1" to not display these messages

■ See "Display Mode and Setting Change Message" (page 57) for a description of setting the display mode

<Notes>

■ The white balance and black balance cannot be adjusted while the setting menu appears on the viewfinder screen. Therefore, be sure to set the MENU SET/OFF switch to OFF

■ ABB must be executed again when the MASTER GAIN values on the LOW SETTING, MID SETTING and HIGH SETTING pages of the setting menu are changed, the S IRIS SW item is set to +30 dB at the FUNCTION 2/5 page of the setting menu, or the GAMMA (ON/OFF) item is switched at the FUNCTION 1/5 page of the setting menu

■ With artificial lights, particularly with fluorescent lights and mercury-arc lamps, the strength of the R, G and B colors changes in synchronization with the power line frequency even if the brightness of these lights appears to be constant. Especially in areas where the power line frequency is 50 Hz, the vertical synchronizing frequency (approx. 60 Hz) of the TV and the frequency (50 Hz) of the lighting tend to interact. This gives rise to flicker and to a phenomenon where the hue changes along with the passage of time, and it is impossible to obtain the proper white balance

These phenomena can be reduced by setting the shutter speed to 1/100. For this reason, whenever the unit is used under fluorescent or mercury-arc lamps and at a frequency of 50 Hz, the shutter speed must be set to 1/100 and the white balance obtained. This shutter speed of 1/100 should also be used during shooting

1 Set the switches as shown in the figure

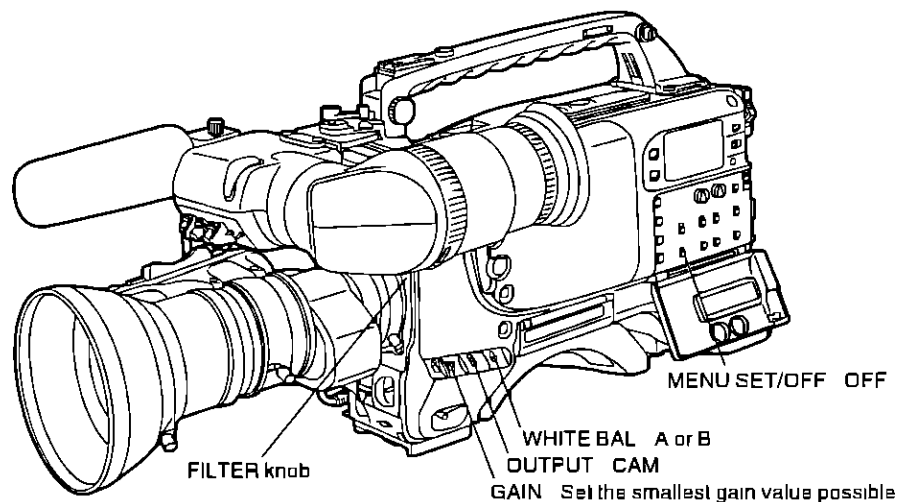

If the settings of the GAIN and WHITE BAL switches are changed, a message informing of the new setting will appear for about 3 seconds at the setting change message display position on the viewfinder screen. (However, the message appears only when the display mode is set to "3")

2 Select the FILTER knob setting in accordance with the lighting conditions

■ See FILTER knob (page 15) in the Shooting (Recording)/Playback Function Section for examples of FILTER knob settings. If the setting of the FILTER knob is changed, a message informing of the new setting will appear for about 3 seconds at the setting change message display position on the viewfinder screen. (However, the message appears only when the display mode is set to "3")

- 3** Place the white pattern over a location with the same conditions as the light source illuminating the subject and zoom up to project white on the screen
A white object (white cloth, white wall) near the subject can also be used. The white area required is as shown below.

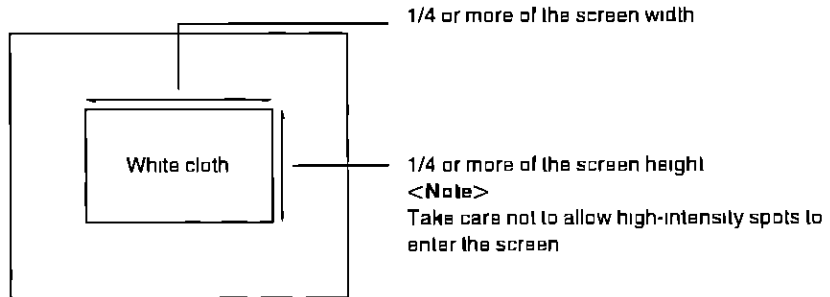

- 4** Adjust the iris of the lens
- 5** Press the AUTO W/B BAL switch to the WHT side and release the switch. The switch returns to the center and the white balance is automatically adjusted.

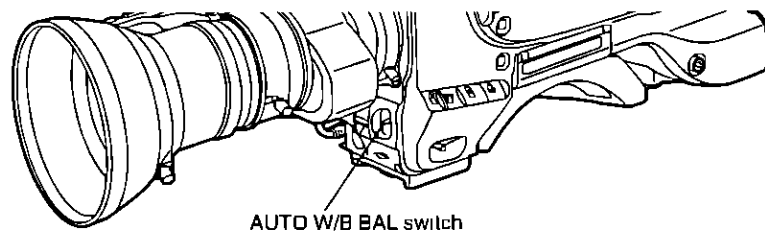

- 6** During the adjustment, the following message appears on the viewfinder screen (However, the message appears only when the display mode is set to "2" or "3")

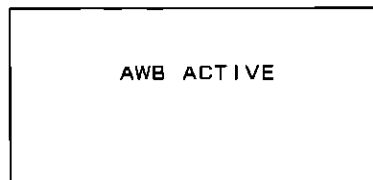

Message during adjustment

- 7** Adjustment is completed after approximately 1 second (the following message appears) and the adjustment value is automatically stored in the memory (A or B) selected in step 1

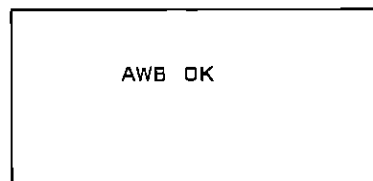

Message after adjustment is completed

<Note>

If a lens equipped with the automatic iris function is used, the iris may experience hunting¹⁾. In these cases, adjust the iris gain knob (the knob marked IG, IS, S, etc.) on the lens.

- See the Handling Instructions for the lens for a detailed description.

1) Hunting The auto iris responds repeatedly causing the image to become darker and brighter.

Adjusting the White Balance/Black Balance

When the White Balance Cannot be Automatically Adjusted

An error message will appear on the viewfinder screen
(The message appears when the display mode is set to "2" or "3")
The displayed messages are as follows

Error messages related to white balance adjustment

| Error message | Meaning | Treatment |
|-----------------|------------------------------------|-----------------------------------|
| COLOR TEMP HIGH | The color temperature is too high | Select an appropriate filter |
| COLOR TEMP LOW | The color temperature is too low | Select an appropriate filter |
| LOW LIGHT | There is insufficient illumination | Increase the illumination or gain |
| LEVEL OVER | There is too much illumination | Decrease the illumination or gain |

If the above error messages appear, carry out the respective treatment attempt to adjust the white balance again

If the error message continues to appear even after repeated attempts, consult your dealer

<Note >

The white balance cannot be adjusted while the setting menu is displayed on the viewfinder screen. Therefore, be sure to set the MENU SET/OFF switch to OFF

When there is no Time to Adjust the White Balance

Set the WHITE BAL switch to PRST

The white balance for the filter is automatically adjusted according to the setting position of the FILTER knob (outside)

White balance memories

The white balance has two memory systems A and B

Adjustment values for each filter can automatically be stored in the memory corresponding to the setting (A or B) of the WHITE BAL switch. The unit contains 4 filters, making a total of 8 (4×2) adjustment values which can be stored

If FILTER INH on the FUNCTION 2/5 page of the setting menu is set to ON, the A and B systems can be limited to one memory each

In this case, the memory contents are not linked to the filters

The black balance must be adjusted in the following cases

- When the unit is used for the first time
- When the unit is first used after an extended period of non-use
- When the unit is used under conditions where the ambient temperature has changed by a wide margin
- When the gain selector value is changed
- When the SUPER IRIS button setting is changed (when setting is changed to +30 dB)
- When the gamma ON/OFF is changed

Adjusting the Black Balance

- 1** Set the switches as shown in the figure

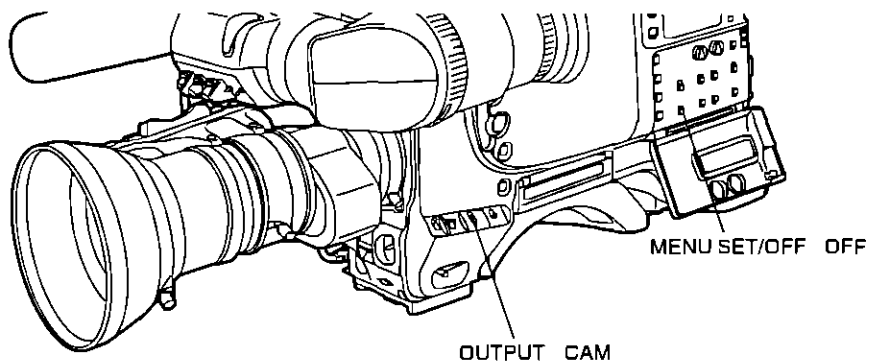

- 2** Press the AUTO W/B BAL switch to the ABB side and then release the switch
The switch returns to the center and the black balance is automatically adjusted

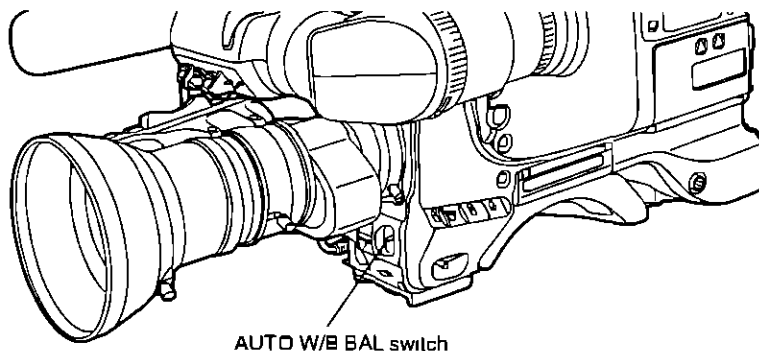

- 3** During the adjustment, the following message will appear on the viewfinder screen (However, the message appears only when the display mode is set to "2" or "3")

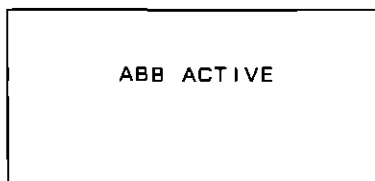

Message during adjustment

- The lens iris automatically goes to the "CLOSE" position during the adjustment

Adjusting the White Balance/Black Balance

- 4** Adjustment is completed after a few seconds (the following message appears) and the adjustment value is automatically stored in the memory

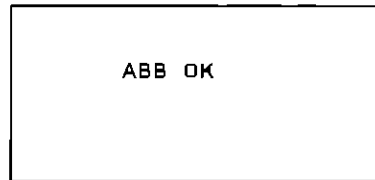

Message after adjustment is completed

<Notes>

- Check that the lens connector is connected and that the iris of the lens is set to CLOSE
- During black balance adjustment, the iris automatically goes to the shaded status
- During black balance adjustment, the gain selector circuit switches automatically
In addition, flicker and noise may appear on the viewfinder screen, but this does not indicate a malfunction
- The black balance cannot be adjusted while the setting menu is displayed on the viewfinder screen. Therefore, be sure to set the MENU SET/OFF switch to OFF
- If black shading is not satisfactory even when ABB is OK, open the AUTO SHADING page of the setting menu and execute black shading adjustment. (See page 123)

Setting the Electronic Shutter

Shutter Modes

The shutter modes which can be used with the unit's electronic shutter and the shutter speeds which can be selected are as follows

Shutter modes and shutter speeds which can be selected

| Mode | Shutter speed | Application |
|--------------|---|--|
| Standard | 1/100, 1/120, 1/250, 1/500, 1/1000 and 1/2000 (seconds) | This mode is used to shoot clear images of quickly moving subjects |
| SYNCHRO SCAN | 248 steps in the range from 30.4 Hz to 250 Hz | This mode is used to reduce horizontal stripe patterns for monitor screens with a vertical scanning frequency of 30 Hz or more |
| SUPER V | | This mode is used to increase the vertical resolution |

<Notes>

- Increasing the shutter speed lowers the camera sensitivity regardless of electronic shutter mode
- If the iris is set to AUTO, the iris opens and the depth of the focuses decreases as the shutter speed rises

Setting the Electronic Shutter

Setting the Shutter Mode/Speed

- The shutter speed during shutter mode and standard mode is set by the SHUTTER switch
- During SYNCHRO SCAN mode, the shutter speed can be set beforehand at the SYNCHRO SCAN page of the setting menu. The shutter speed can also be set by the UP and DOWN buttons during SYNCHRO SCAN mode. (In addition, if S SCAN SEL on the FUNCTION 2/5 page of the setting menu is set to ON, the shutter speed can also be varied by the SUPER IRIS and MODE CHECK switches on the side panel. However, note that the SUPER IRIS and MODE CHECK functions do not operate at this time.)
- The shutter speed selection range can be limited to the required range and whether to use special operation modes (SYNCHRO SCAN or SUPER V) can be selected at the SHUTTER SPEED page of the setting menu.

Setting the shutter mode/speed

- 1 Perform the operations outlined in "Changing the Display Mode" (page 58) and set the display mode to "2" or "3" at the VF DISPLAY page of the setting menu.
- 2 Press the SHUTTER switch from the ON position to the SEL side. The current shutter setting appears in the setting change message display position on the viewfinder screen.
Ex 1/120, 1/617, etc

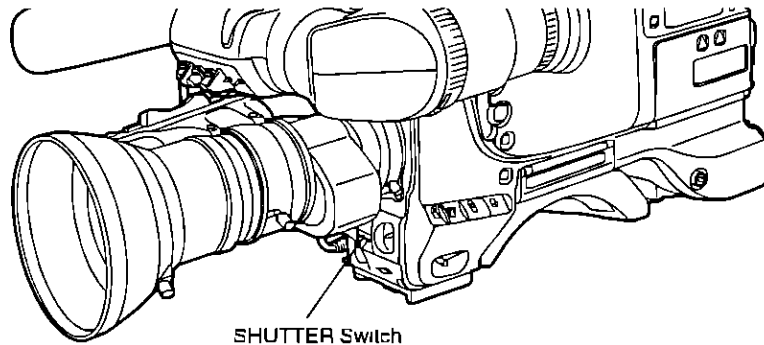

- 3 Press the SHUTTER switch to the SEL side repeatedly until the desired mode or speed appears. When all modes and speeds can be displayed, the display changes in the order shown below. If the required shutter speeds and modes have been designated beforehand, only the designated speeds or modes appear.

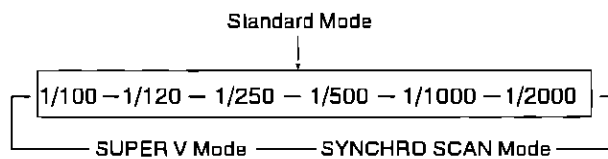

- When the unit is shipped from the factory, SUPER V mode is not specified and is therefore not displayed.

Setting the Synchro Scan Mode

- 1** Set the MENU SET/OFF switch to SET
The page on which the previous setting menu operations were completed appears on the viewfinder screen (When the menu is used for the first time, the first page appears)
- 2** Press the PAGE button repeatedly until the SYNCHRO SCAN page shown below appears
(This operation can also be performed using the PAGE+UP/DOWN function)

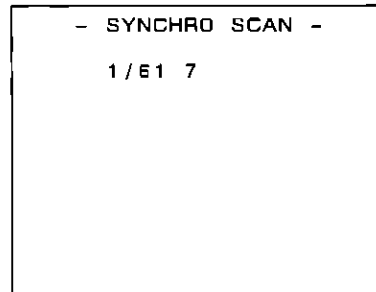

- 3** Press the UP (the value increases) or DOWN (the value decreases) button repeatedly to display the desired frequency. The frequency can be switched continuously within the range of 30.4 Hz to 250.0 Hz
- 4** When menu operations have been completed, set the MENU SET/OFF switch to OFF. The setting menu disappears from the viewfinder screen and the displays indicating the unit's current status appear at the top and bottom of the viewfinder screen.
(If S SCAN MODE SEL on the FUNCTION 2/5 page of the setting menu is set to ON, the shutter speed can be varied by the SUPER IRIS and MODE CHECK switches. However, care should be taken at this time as the SUPER IRIS and MODE CHECK functions cannot be operated only during SYNCHRO SCAN mode.)

Setting the Electronic Shutter

Changing the Shutter Speed/Mode Selection Range

The shutter speed selection range can be limited to the required range and whether to use a special operation mode can be selected at the SHUTTER SPEED page of the setting menu. The unit is set so that the SHUTTER SPEED page is not displayed when shipped from the factory. To operate the SHUTTER SPEED page, switch the unit to engineer mode or select the SHUTTER SPEED page at the MENU SELECT page beforehand.

- 1** Set the MENU SET/OFF switch to SET
The page on which the previous setting menu operations were completed appears on the viewfinder screen. (When the menu is used for the first time, the first page appears.)
- 2** Press the PAGE button repeatedly until the SHUTTER SPEED page shown below appears. (This operation can also be performed using the PAGE+UP/DOWN function.)

```
- SHUTTER SPEED -  
- - SYNCHRO SCAN  
  SUPER V  
  * 1 / 100  
  - 1 / 120  
  - 1 / 250  
  - 1 / 500  
  - 1 / 1000  
  - 1 / 2000
```

<Note>

The ON/OFF status for each item is indicated by displaying an asterisk (*) or period (.) in front of the item on the screen.

- 3** Press the SHIFT/ITEM button repeatedly to move the cursor to the position of the mode or shutter speed to be set.
- 4** The selected mode or speed changes from used (ON) to not used (OFF) and vice versa each time the UP (or DOWN) button is pressed.
- 5** When menu operations have been completed, set the MENU SET/OFF switch to OFF. The setting menu disappears from the viewfinder screen and the displays indicating the unit's current status appear at the top and bottom of the viewfinder screen.

<Note>

When operating the unit from the AQ-EC1 extension control unit (option), even if the SHUTTER SPEED page is operated from the unit, the switches of the AQ-EC1 have priority regarding the actual shutter speed.

- See "Setting Menu Configuration" (page 47) for a description of engineering mode and selecting display pages.

Changing the Iris Automatic Adjustment Reference Value

To change the reference value, change the A IRIS LEVEL value on the LEVEL 6/6 page of the setting menu using the UP or DOWN button.

Adjusting the Audio Level

If the AUTO SELECT CH1/CH2 selector switch is set to AUTO, the input levels of audio CH1 and CH2 are automatically adjusted. If the level of audio channels 1 and 2 is to be manually adjusted, perform the following operations:

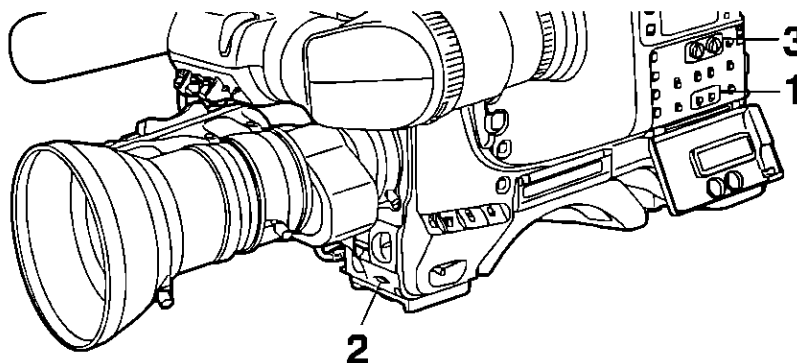

Manually Adjusting the Audio Level

- 1 Set the AUTO SELECT CH1/CH2 selector switch to MAN
- 2 Turn the AUDIO LEVEL CH1 control at the bottom of the front panel completely to the right
- 3 Turn the AUDIO LEVEL CH1/CH2 controls to adjust the audio level so that the level meter appears up to 0 dB at the maximum volume

Limiter

When the audio level is adjusted manually, the limiter circuit operates with respect to excessive input. Limiter circuit operation can be set to ON and OFF at the setting menu.

Adjusting the Audio CH1 Level from the Viewfinder

The audio CH1 level can be adjusted by the AUDIO LEVEL CH1 control at the bottom of the front panel while watching the viewfinder.

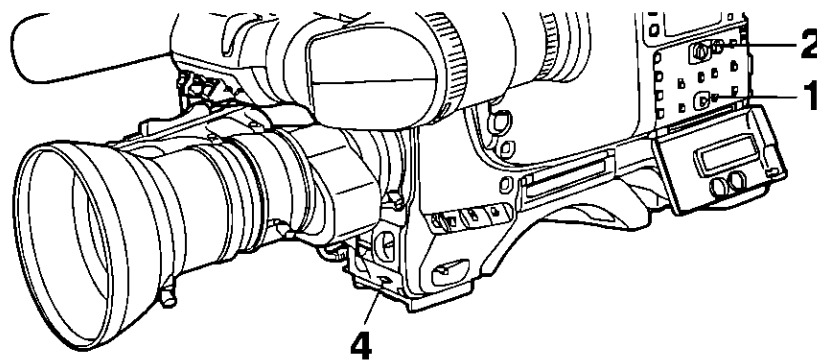

- 1 Set the AUTO SELECT CH1 switch to MAN
- 2 Turn the AUDIO LEVEL CH1 control on the side panel completely to the right
- 3 Set LEVEL METER on the VF DISPLAY page of the setting menu to ON. The audio level display appears on the viewfinder screen.

Adjusting the Audio Level

- 4** Turn the AUDIO LEVEL CH1 control at the bottom of the front panel to adjust the input volume so that the audio level display appears as shown below
- When the input volume is normal, the audio level display turns ON up to the sixth of the seven level display bars from the left
 - When the rightmost (0 dB) turns asterisk (*) mark, the input volume is excessive. Adjust the level so that the seventh (0 dB) does not turn * mark

— — — □ — — *

-40 -30 -25 -20 -15 -8 0

When the optimal level cannot be set

The maximum attenuation of the AUDIO LEVEL CH1 control at the bottom of the front panel is about 20 dB. When the optimal level cannot be set within this range, adjust the level using the AUDIO LEVEL CH1 control on the side panel.

Using the AUDIO LEVEL CH1 controls at the bottom of the front panel and on the side panel

Normally, the control at the bottom of the front panel is turned completely to the right and the recording level is adjusted using the control on the side panel.

The control at the bottom of the front panel is used to throttle the level when the input level increases suddenly during recording.

Setting the Time Data

Setting the Time Code

When using both the user bit and the time code, set the user bit first. If the time code is set first, the time code generator will stop while the user bit is being set, causing the set time code to become inaccurate. The time code can be set within the range of 00 00 00 00 to 23 59 59 29.

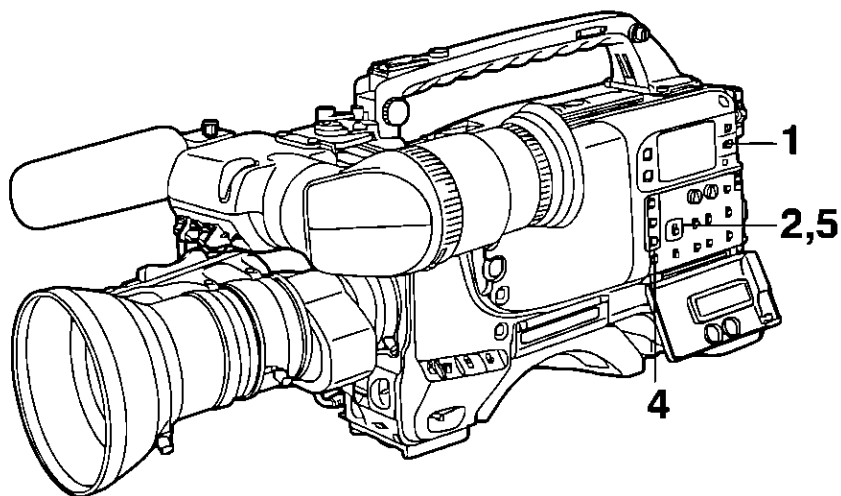

- 1** Set the DISPLAY switch to TC
- 2** Set the TCG switch to SET
- 3** Set TC MODE on the FUNCTION 3/5 page of the setting menu to DF or NDF. Select DF when the time code is to be advanced during drop frame mode, and NDF when the time code is to be advanced during non-drop frame mode.
- 4** Set the time code using the SHIFT/ITEM, UP and DOWN buttons.
SHIFT/ITEM button This is used to cause the digit which is to be set to flash. Each time it is pressed, the flashing digit moves to the right.
UP button This increments by 1 the figure of the flashing digit.
DOWN button This decrements by 1 the figure of the flashing digit.
- 5** Set the TCG switch.
Set the switch to F-RUN when the time code is to be advanced regardless of the VTR's operation.
Set the switch to R-RUN when the time code is to be advanced only while recording is in progress.

Time code status during battery replacement

The back-up mechanism functions even while replacing the battery to allow the time code generator to continue operating for extended periods of time (approx. 1 year).

Setting the Time Data

Setting the User Bit

Setting the user bit allows up to 8 digits of hexadecimal data such as memos (date, time), etc. to be recorded in the sub code track

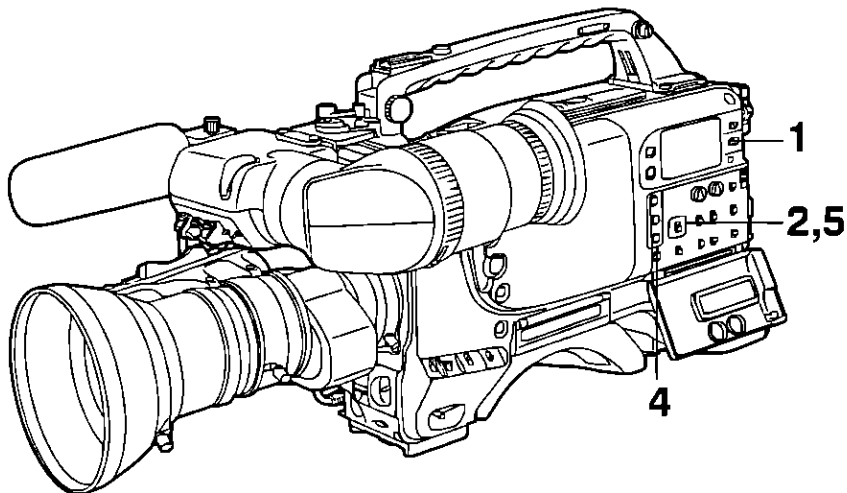

- 1** Set the DISPLAY switch to UB
- 2** Set the TCG switch to SET
- 3** Set UB MODE on the FUNCTION 3/5 page of the setting menu to REAL
- 4** Set the user bit using the SHIFT/ITEM, UP and DOWN buttons
SHIFT/ITEM button This is used to cause the digit which is to be set to flash. Each time it is pressed, the flashing digit moves to the right.
UP/DOWN buttons These increment/decrement by 1 the figure of the flashing digit.

The hexadecimal characters A to F appear as follows

| Hexadecimal | A | B | C | D | E | F |
|-------------|---|---|---|---|---|---|
| Display | A | b | c | d | E | F |

- 5** Set the F-RUN/R-RUN switch to F-RUN or R-RUN

User bit memory function

The user bit setting (except for the real time) is automatically stored in the memory and held even after the power is turned off. However, care should be taken as the settings are not stored in the memory if the time from when the power was turned on until the setting operations are completed and the power is turned off is less than 20 seconds.

Locking the Time Code to an External Source

The time code generator of the VTR section can be locked to an external generator

Example of connections for external locking

Example 1 Locking the time code to an external signal

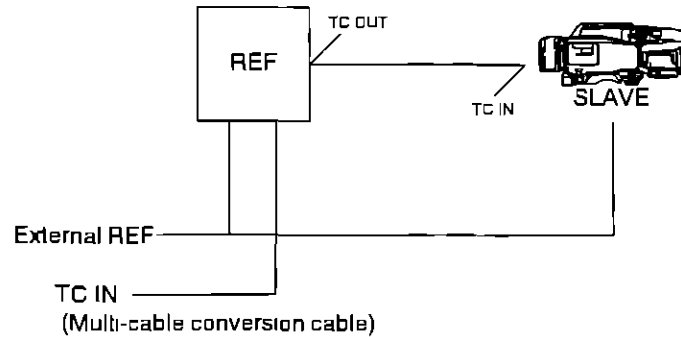

Example 2 Connecting multiple units and using one unit as the reference

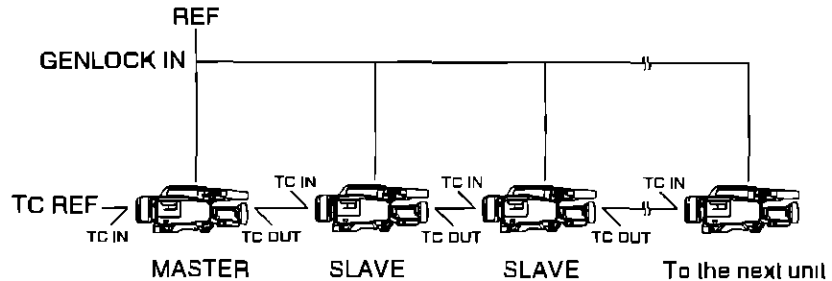

Setting the Time Data

External lock operation procedure

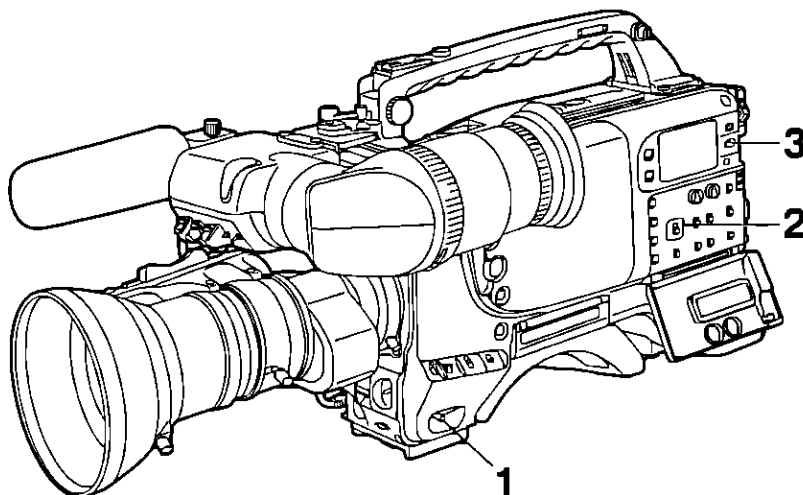

- 1** Set the POWER switch to ON
- 2** Set the F-RUN/R-RUN switch to F-RUN
- 3** Set the DISPLAY switch to TC
- 4** Supply reference time code and reference video signals with a phase relationship which meets the time code standards to the TC IN and GENLOCK IN connectors, respectively

This locks the built-in time code generator to the reference time code. After about 10 seconds have passed since the time code generator was locked, the external lock status is maintained even if the external reference time code is disconnected. However, if the reference time code is disconnected during recording (REC), the servo lock will be thrown out of order.

<Note>

When the external locking operation is performed, the time code is locked instantly to the external time code and the same value as the external code value appears in the counter display position. Do not set the VTR to recording mode for several seconds until the sync generator has stabilized.

Setting Time Data

User bit setting during external locking

When the time code is locked to an external source, only the time data is locked to the time data of the time code from the external source. Accordingly, the user bit can be set independently for each unit. The user bit can also be locked to the user bit of the time code from the external source.

- Consult your dealer for a detailed explanation.

Releasing the external lock

Stop supplying the external time code and then set the F-RUN/R-RUN switch to R-RUN.

Switching the power supply from the battery to an external power supply during external locking

In order to maintain power supply continuity for the time code generator, connect the external power supply to the DC IN connector before unplugging the battery pack. If the battery pack is unplugged first, the external locking continuity of the time code cannot be assured.

Synchronizing the camera section to an outside source during external locking

While the time code is locked to an external source, the camera section is genlocked by the reference video signal input to the GENLOCK IN connector.

Setting menu contents can be stored using setup cards (option). This data can then be used to quickly recreate the appropriate setup conditions. Subject data, etc. can also be stored on setup cards. See the Setup Card Application Instructions for a detailed description.

- Setup cards are optional, and general purpose memory cards (S RAM 64 Kbyte or more) can be used.

Setup Card Handling

Setup cards can be inserted and ejected regardless of whether the power is on or off. However, setup cards should not be inserted or ejected during recording as this may result in misoperation.

Ejecting setup cards

Lift up on the lower edge of the cover to open the cover and remove the setup card.

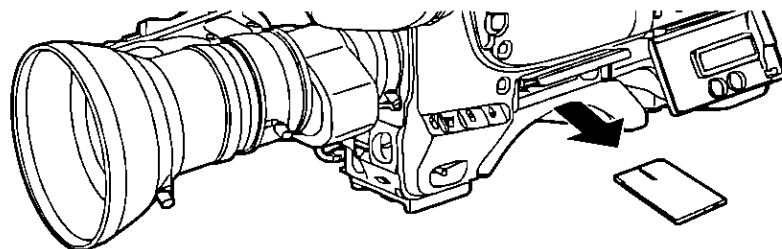

<Note>

Take care not to touch the connectors at the front of the setup card.

Inserting setup cards

Position the unit so that the panel with the logo faces you, insert the setup card into the setup card insertion slot and then close the cover.

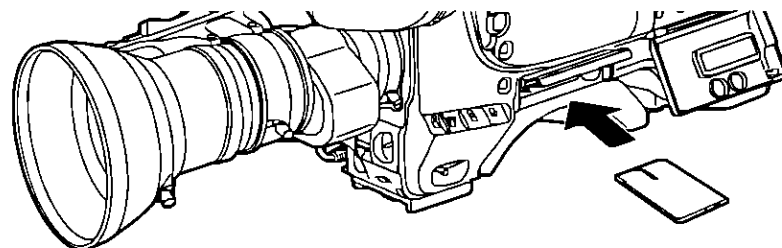

<Note>

Check that the unit is positioned with the logo facing you and that the characters are facing the correct direction, and then insert the card. Be sure to insert the card in the correct direction. If the card is difficult to insert, the card may be backwards or upside-down. In these cases, do not attempt to force in the card, but check whether the card is backwards or upside-down and then reinsert the card.

Usage and storage precautions

The following points should be observed when using and storing setup cards:

- Avoid high temperatures and humidity.
- Do not expose setup cards to water.
- Avoid electrostatic charges.

Store setup cards inserted in the unit with the cover closed.

Setup Card Operations

Setup Card Data Operations

Operations to store setting data on setup cards and read out stored data are performed at the SET UP CARD page of the setting menu

<Note>

When operating the unit with a remote controller, the SET UP CARD page cannot be operated from the unit

Formatting setup cards

- 1 Set the MENU SET/OFF switch to SET. The page on which the previous setting menu operations were completed appears on the viewfinder screen. (When the menu is used for the first time, the first page appears.)
- 2 Press the MENU switch repeatedly until the SET UP CARD page shown below appears. (This operation can also be performed using the PAGE+UP/DOWN function.)

```
  - SET UP CARD -  
  -READ (-CAM)  
  WRITE (-CARD)  
  CARD CONFIG  
  ID READ/WRITE  ON
```

- 3 Press the SHIFT/ITEM button repeatedly to move the cursor to the CARD CONFIG position.
- 4 Press the UP (or DOWN) button. When the setup card has been formatted, the message shown below appears.

<Note>

When setup cards are formatted, the setting conditions at that time are also input simultaneously.

```
  - SET UP CARD -  
  READ (-CAM)  
  WRITE (-CARD)  
  -CARD CONFIG  
  ID READ/WRITE  ON  
  
  FORMAT OK
```

- 5 When menu operations have been completed, return the MENU SET/OFF switch to OFF. The setting menu disappears from the viewfinder screen and the displays indicating the unit's current status appear at the top and bottom of the viewfinder screen.

When data is not written

If the following error messages appear when the UP (or DOWN) button is pressed in step 4, the data is not written

Data format error messages

| Error message | Condition | Countermeasure |
|----------------------|---|---|
| WRITE PROTECT | The write protect switch on the side of the card is set to ON | Set the write protect switch on the side of the card to OFF |
| NO CARD | A setup card is not inserted | Insert a card |
| ERROR | The disk cannot be formatted | The card may be defective Replace the card |

Setup Card Operations

Writing set data to cards

- 1** Set the MENU SET/OFF switch to SET. The page on which the previous setting menu operations were completed appears on the viewfinder screen. (When the menu is used for the first time, the first page appears.)
- 2** Press the MENU switch repeatedly until the SET UP CARD page shown below appears. (This operation can also be performed using the PAGE+UP/DOWN function.)

```
  - SET UP CARD -  
-READ (-CAM)  
WRITE (-CARD)  
CARD CONFIG  
ID READ/WRITE ON
```

- 3** Press the SHIFT/ITEM button repeatedly to move the cursor to the WRITE (→CARD) position.
- 4** Press the UP (or DOWN) button. When writing is complete, the message shown below appears.

```
  - SET UP CARD -  
  READ (-CAM)  
-WRITE (-CARD)  
  CARD CONFIG  
  ID READ/WRITE ON  
  
      WRITE OK
```

- 5** When menu operations have been completed, return the MENU SET/OFF switch to OFF. The setting menu disappears from the viewfinder screen and the displays indicating the unit's current status appear at the top and bottom of the viewfinder screen.

Protecting stored data

If the setup card's WRITE PROTECT switch is set to ON, data is not rewritten even if the UP (or DOWN) button is pressed in step 4

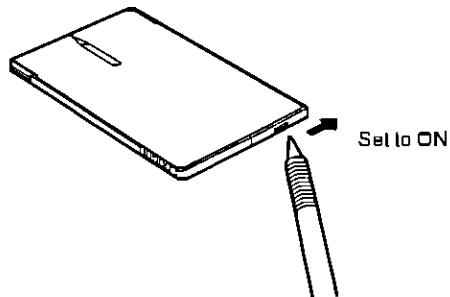

When data is not written

If the following error messages appear when the UP (or DOWN) button is pressed in step 4, the data is not written

Data writing error messages

| Error message | Condition | Countermeasure |
|----------------------|---|---|
| NO CONFIG | The setup card is not formatted | Format the card |
| NO CARD | A setup card is not inserted | Insert a card |
| WRITE PROTECT | The write protect switch on the side of the card is set to ON | Set the write protect switch on the side of the card to OFF |
| ERROR | Data cannot be written on the card | The card may be defective Replace the card |

Setup Card Operations

Reading out data stored on cards

- 1 Set the MENU SET/OFF switch to SET. The page on which the previous setting menu operations were completed appears on the viewfinder screen. (When the menu is used for the first time, the first page appears.)
- 2 Press the PAGE switch repeatedly until the SET UP CARD page shown below appears. (This operation can also be performed using the PAGE+UP/DOWN function.)

```
- SET UP CARD -  
-READ (-CAM)  
WRITE (-CARD)  
CARD CONFIG  
ID READ/WRITE ON
```

- 3 Press the SHIFT/ITEM button to move the cursor to the READ (→CAM) position.
- 4 Press the UP (or DOWN) button. When readout is complete, the message shown below appears.

```
- SET UP CARD -  
-READ (-CAM)  
WRITE (-CARD)  
CARD CONFIG  
ID READ/WRITE ON  
  
READ OK
```

- 5 When menu operations have been completed, set the MENU SET/OFF switch to OFF. The setting menu disappears from the viewfinder screen and the displays indicating the unit's current status based on the data read out from the setup card appear at the top and bottom of the viewfinder screen.

When data is not read out

If the following error messages appear when the UP (or DOWN) button is pressed in step 4, the data is not read out.

Data readout error messages

| Error message | Condition | Countermeasure |
|---------------|----------------------------------|--|
| NO CONFIG | The setup card is not formatted. | Format the card. |
| NO CARD | A setup card is not inserted. | Insert a card. |
| ERROR | Data cannot be read out. | Data written by devices other than this unit cannot be read out. |

Cassettes

▪ See "Cassettes" (page 135) for a description of cassettes which can be used with the unit

Inserting and Ejecting Cassettes

Inserting cassettes

- 1 Check that there are no cables, etc. around the cassette holder and the top panel and then set the POWER switch to ON

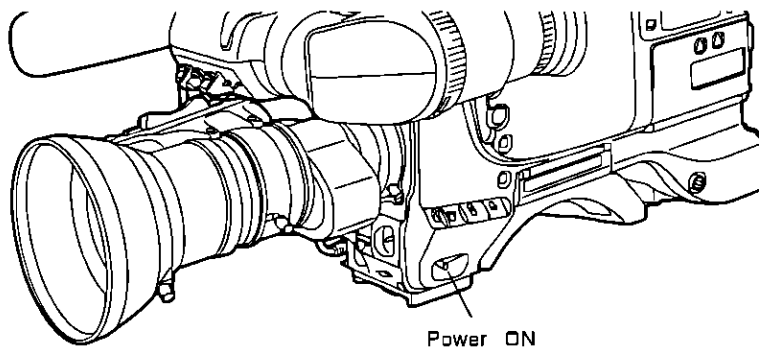

If condensation has occurred inside the unit, the HUMID display lights. In these cases, wait until the display goes off before proceeding to step 2

- 2 Press the EJECT button. The cassette holder opens

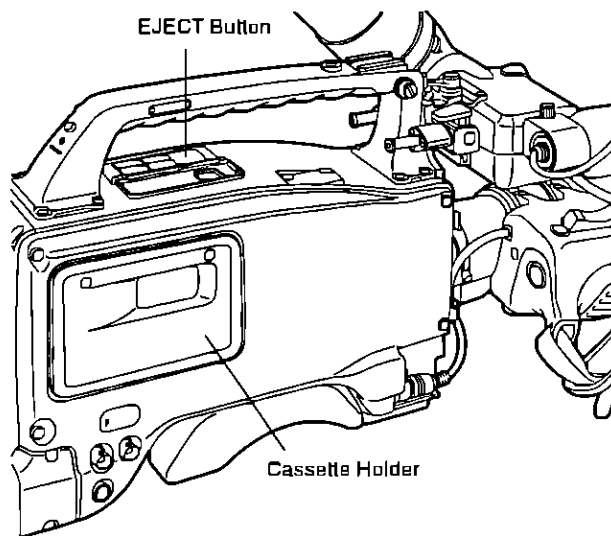

- 3 Check that there is no slack in the tape, insert the cassette, and then firmly close the cassette holder

Checking that there is no slack in the tape

Press the reel in with your finger and turn it lightly in the direction of the arrow. If the reel does not turn, there is no slack in the tape

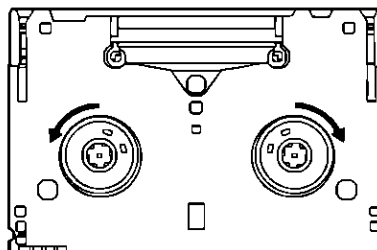

Cassettes

Ejecting cassettes

With the power turned on, press the EJECT button to open the cassette holder and eject the cassette. If a cassette is not to be inserted immediately after ejecting the cassette, close the cassette holder.

Ejecting cassettes when the battery has run out

Set the POWER switch to OFF to turn off the power, then turn on the power again and immediately hold down the EJECT button. If there is still power remaining in the battery, the cassette will be ejected. However, this operation should not be repeated.

Preventing Accidental Erasure

Set the tab on the cassette to the SAVE side to prevent the recorded contents of tapes from being accidentally erased.

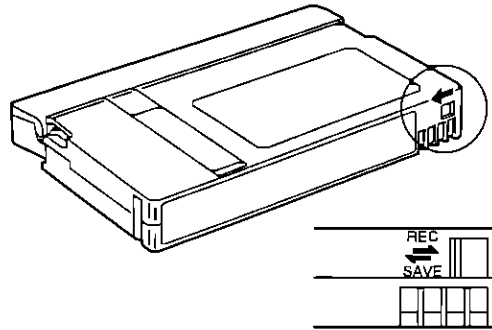

Recording

Basic Procedures

This section describes the basic operating procedures for shooting and recording. When starting to shoot actual images, inspect the unit beforehand to check that all systems are functioning normally.

- See the "Inspections Before Shooting" (page 128) for a description of inspection procedures.

Procedures from power supply preparations to inserting a cassette

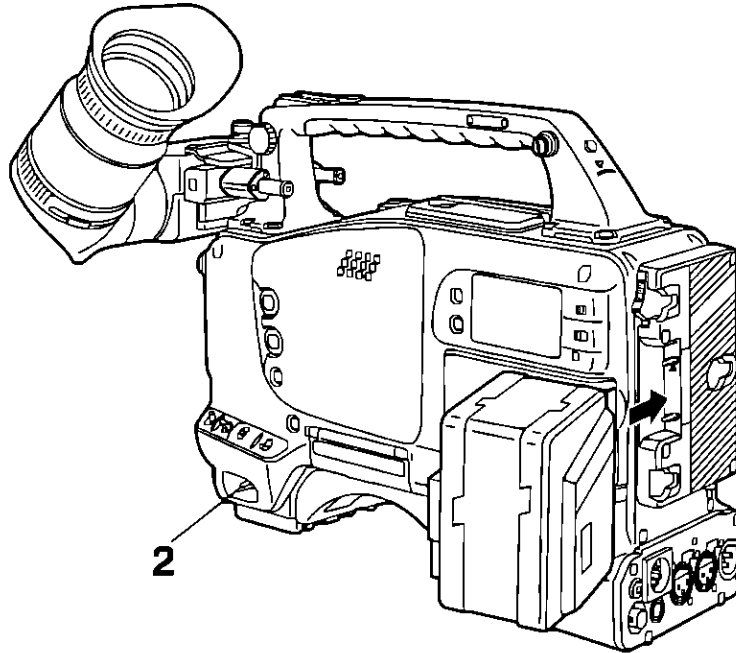

- 1** Insert a charged battery pack
- 2** Set the POWER switch to ON and check that the HUMID display does not appear and that five or more bars of the remaining battery level display are lighted
 - If the HUMID display appears, wait until the display goes off
 - If five or more bars of the remaining battery level display are not lighted, replace the battery pack with a sufficiently charged battery pack
- 3** Check that there are no cables, etc. around the cassette holder and top panel and then press the EJECT button to open the cassette holder
- 4** Check the following items, and then insert a cassette and close the cassette holder
 - The cassette is not set to write protect status
 - There is no slack in the tape

Recording

Procedures from adjusting the white balance and black balance to stopping recording

Turn on the power, insert a cassette, and then set the various switches as follows

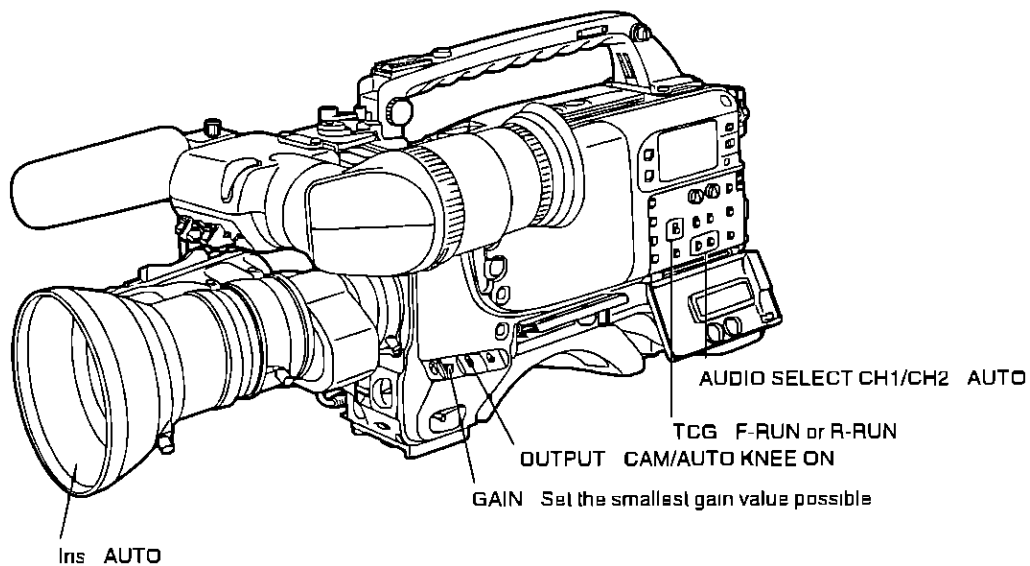

Shooting images

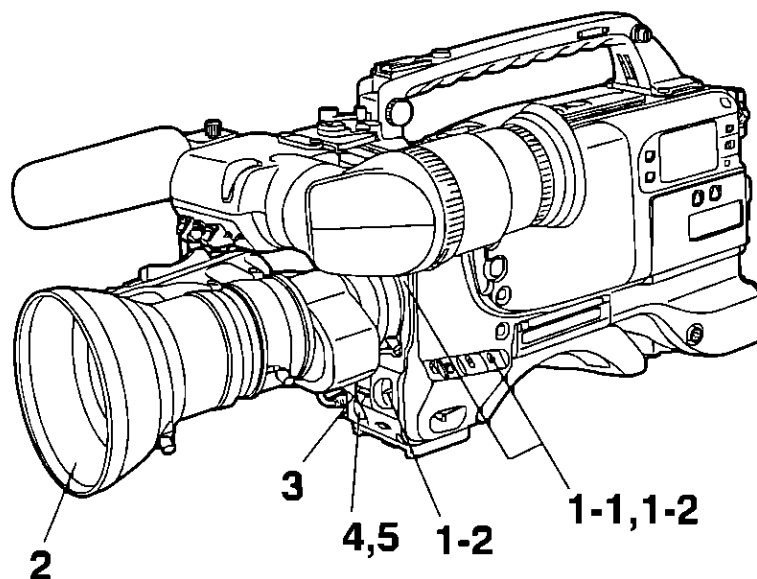

- 1-1** Select the filter in accordance with the lighting conditions, and when the white balance has already been stored in the memory, set the WHITE BAL switch to "A" or "B"
When the white balance and black balance have not been stored in the memory and there is no time to adjust the white balance
Set the WHITE BAL switch to PRST and set the FILTER knob to "1" this will achieve a 3200 K white balance (If the knob is set to any other position, a 5600 K white balance is achieved)
- 1-2** To adjust the white balance on site, select the filter which corresponds with the lighting conditions, set the WHITE BAL switch to "A" or "B", and adjust the white balance by following the steps below
- (1) Press the AUDIO W/B BAL switch to the AWB side to adjust the white balance
 - (2) Press the AUTO W/B BAL switch to the ABB side to adjust the black balance
 - (3) Press the AUTO W/B BAL switch to the AWB side to adjust the white balance
- For details on how to adjust the white balance, read through the section entitled "Adjusting the white balance/black balance" (page 66)
- 2** Aim the camera at the subject and adjust the focus and zoom
- 3** When using the electronic shutter, set the shutter speed and operation mode
▪ See "Setting the Electronic Shutter" (page 71) for a detailed description
- 4** Press the VTR START button of the unit or the VTR button of the lens to start recording The REC lamp inside the viewfinder lights during recording
- 5** Press the VTR START button again to stop recording The REC lamp inside the viewfinder goes off

Tape operation buttons

The tape operation buttons (EJECT, REW, FF, PLAY, STOP) do not function during recording

Recording

Successive Shooting

Successive shooting with an accuracy of within ± 1 frame can be performed simply by pressing the VTR START button of the unit or the VTR button of the lens while recording is paused

While recording is paused

The unit automatically searches for the successive shooting point. However, the time until recording starts differs according to the setting of the VTR SAVE/STBY switch.

- If the VTR SAVE/STBY switch is set to SAVE, recording starts about 2 seconds after the VTR START button is pressed.
- If the VTR SAVE/STBY switch is set to STBY, recording starts immediately after the VTR START button is pressed.

Successive shooting when the power is turned off while recording is paused

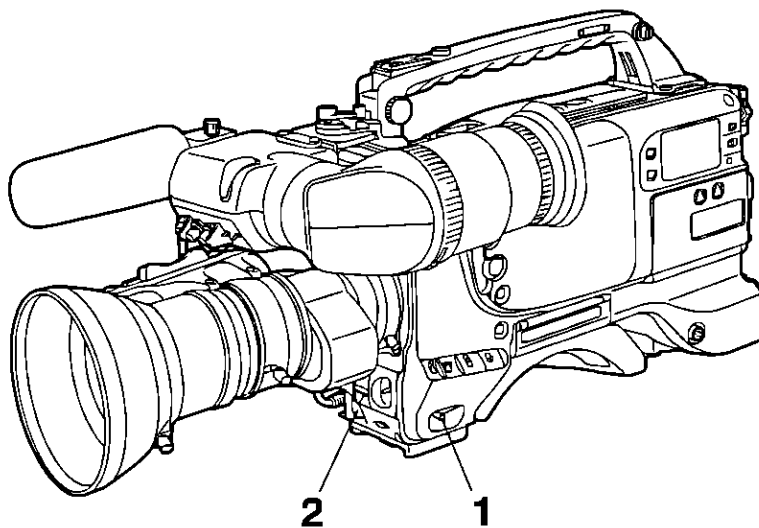

- 1** Turn the power back on
- 2** Press the VTR START button of the unit or the VTR button of the lens to start recording

Successive Shooting in Other Cases

If successive shooting is to be performed after the tape has been run, the cassette has been ejected, or when using a tape which has only been recorded part-way, follow the procedures outlined below

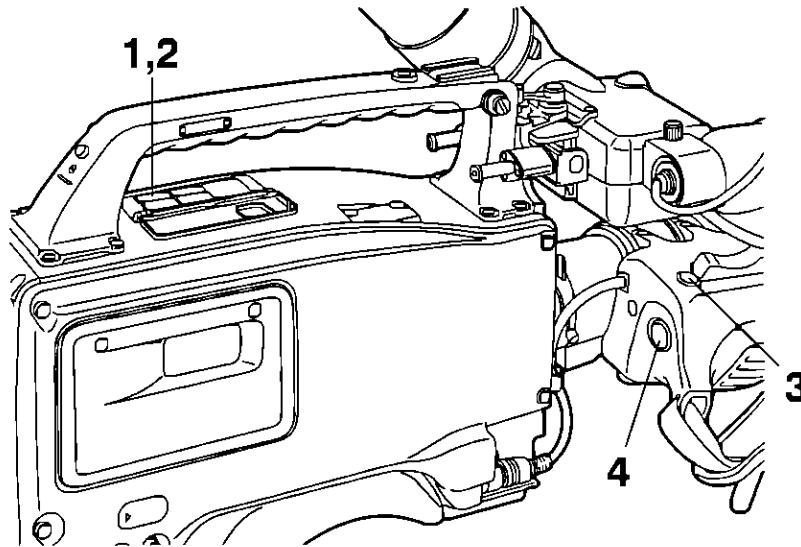

Performing successive shooting after the tape has been run, the cassette has been ejected, or when using a tape which has only been recorded part-way

- 1** Press the PLAY button while watching the viewfinder screen and play back the tape
- 2** At the place where continuity between frames is to be provided, press the PLAY (or STOP) button again to stop the tape
- 3** Press the RET button on the lens. Preparations for frame-to-frame continuity are made about two seconds later
- 4** Press the VTR START button of the unit or the VTR button of the lens to start recording

Playback—Checking Recorded Contents

Pressing the PLAY button allows black-and-white playback images to be viewed on the viewfinder. Playback images can also be viewed in two other ways:

- **Rec review.** If the RET VIDEO switch is set to the INT side, black-and-white images of the last 2 seconds of the recorded contents can be seen on the viewfinder.
- **Color playback.** Connecting a color monitor to the unit's MONITOR OUT connector allows color playback images to be viewed on the monitor.

The playback signal is output to the viewfinder even during rewind (REW) and fast forward (FF). Audio output selection and volume adjustment for the playback signal are performed by the MONITOR switches and knobs on page 13.

Rec Review

If recording is paused and the RET button on the lens is pressed, the tape is automatically rewound and the playback images for the last two seconds appear on the viewfinder. This allows the recording status to be checked.

After playback, the unit returns to the recording start standby status. Holding down the RET button rewinds and plays back up to 10 seconds of the tape.

- See "Selecting Functions" (page 65) for a description of CAM RET function settings.

<Note>

The rec review function cannot be used unless recording has been performed for more than 1 second.

Color Playback

Connecting a color monitor to the VIDEO OUT connector of the unit allows color playback images to be viewed on the monitor.

Connection With an External VTR

The unit is equipped with an interface which enables recording to be performed by an external VTR

- Mounting the AJ-YA700P 26-pin output adaptor (option) and connecting the 26-pin cable (option) to the unit allows recording to be performed by the VTR section (internal VTR) of the unit and an external VTR. The component video signal is output from the 26-pin interface

Precautions When Connecting an External VTR

Set 26P CONTROL on the FUNCTION 3/5 page of the setting menu to BOTH or ON (The setting is OFF when shipped from the factory)

Power supply

Power is not supplied or received between the unit and the external VTR, so special power supplies should be provided for each unit. The BATT lamp and remaining battery level display function inside the viewfinder indicate the power supply status only for the internal VTR. The power supply status for the external VTR should be checked at the external VTR.

TALLY lamp and REC lamp operation

The unit's TALLY lamp and the REC lamp inside the viewfinder indicate the REC status of the unit when 26P CONTROL is set to BOTH. When 26P CONTROL is set to ON, these lamps indicate the REC status of the external VTR.

Warning tone

External VTR-related warning tones are not output from the unit's speaker or PHONES jack.

Note on connecting cables

The signals may not be connected properly with some cables.

The signal assignments for the 26-pin output adaptor AJ-YA700P (optional) are shown in the following table. Use this table as a reference for connection with an external VTR.

| Pin No | Signal | Pin No | Signal |
|--------|------------------------|--------|--------------------|
| 1 | Composite video signal | 8 | P _B GND |
| 2 | Composite video GND | 9 | CAM MIC (H) |
| 3 | Y GND | 10 | CAM MIC (C) |
| 4 | Y signal | 11 | CAM MIC (GND) |
| 5 | P _R signal | 12 | VTR START/STOP |
| 6 | P _R GND | 15 | REC TALLY |
| 7 | P _B signal | B | GND |

Recording Simultaneously with the Internal VTR and an External VTR

Connections

Mount the AJ-YA700P 26-pin output adaptor (option) to the unit, connect the external VTR with the 26-pin cable, and set the audio input level selector switch of the external VTR to “-60 dB” SW3101 and SW3102 on the CAM ENC Printed Circuit Board of the unit must be set to the 26P side (See page 98)

Audio input level selector switch -60 dB

Portable VTR
(Set the audio input level selector switch to -60 dB)

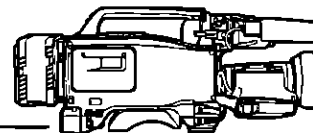

To the 26-pin connector of the AJ-YA700P
(See the following page for mounting the 26-pin output adaptor)

Checking the Function Settings

Check that the settings of the functions which control the 26-pin interface are set to BOTH or ON at the FUNCTION 3/5 page of the setting menu. See “Selecting Functions” for a description of the various function settings.

Starting Recording

- 1 Operate the external VTR and set it to recording paused status.
- 2 Press the VTR START button of the unit or the VTR button of the lens. The internal and external VTRs start recording simultaneously. Pressing the button again sets both VTRs to the recording paused status.

If One VTR Comes to the End of its Tape During Recording

Even if one VTR comes to the end of its tape and stops, the other VTR continues recording operation.

Returning the VTRs to simultaneous recording status

- If the internal VTR came to the end of its tape, replace the cassette and press the VTR START button of the unit or the VTR button of the lens. The external VTR continues recording operation during this time.
- If the external VTR came to the end of its tape, replace the cassette and operate the external VTR to restart recording. The internal VTR continues recording operation during this time.

<Note>

Care should be taken as the internal VTR will assume recording paused status if the VTR START button of the unit or the VTR button of the lens is pressed after replacing the external VTR's cassette.

Functions of the Unit's VTR SAVE/STBY Switch

Tape running mode

Pressing the unit's STOP, REW or FF buttons sets the internal VTR to stop, rewind or fast forward modes, respectively. However, the external VTR is set to recording paused status in all cases.

Viewing playback images on the viewfinder

Pressing the unit's PLAY button allows black-and-white playback images from the internal VTR tape to be viewed on the viewfinder. Playback images from the external VTR cannot be viewed.

Recording With an External VTR Instead of the Internal VTR

Using the 26-pin Output Adaptor

Connections

The method of connecting the external VTR is the same as that described in "Recording Simultaneously with the Internal VTR and an External VTR"

- See "Connections" on page 95

Mounting the 26-pin output adaptor

- Consult your local dealer when mounting the adaptor

- 1 Set the unit's internal switches
 - 1 Remove the side panel on the display window side
 - 2 Remove the Printed Circuit Board holder and remove the CAMERA ENC Printed Circuit Board
 - 3 Set SW101 and SW102 to the 26P side

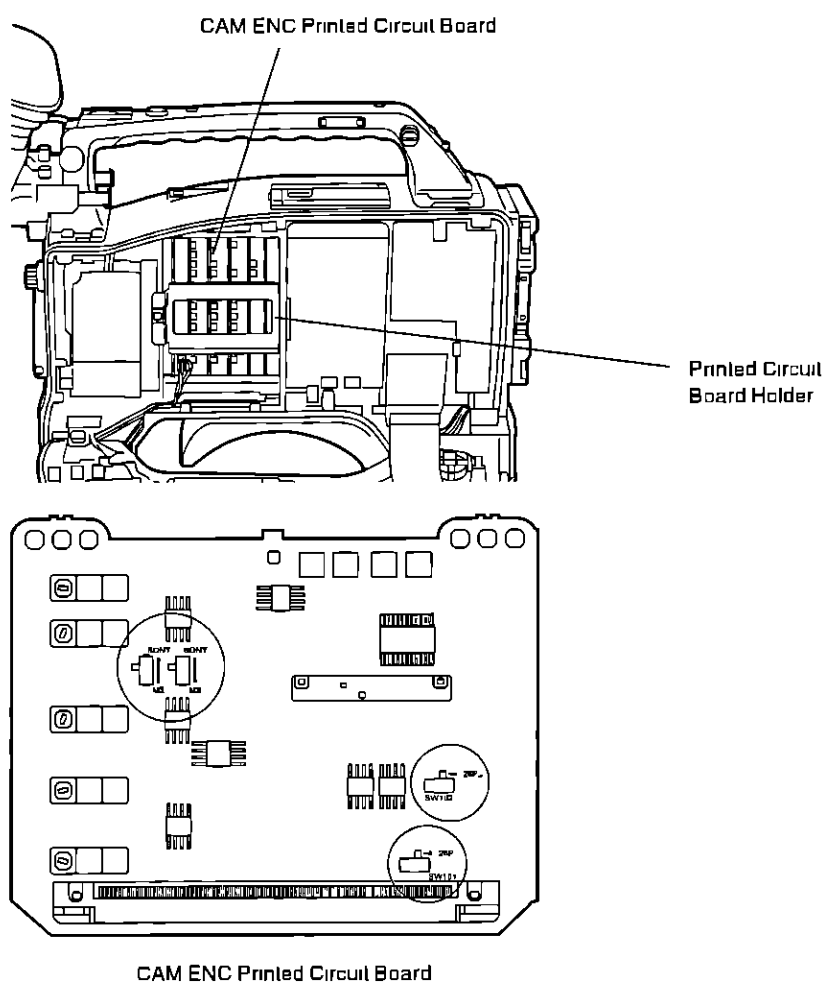

- 2 Mount the 26-pin output adaptor

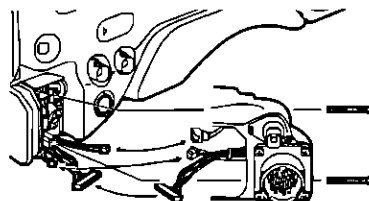

Controlling the external VTR with the unit's switches

Setting the 26P CONTROL function as indicated below at the FUNCTION 3/5 page of the setting menu prevents the internal VTR from being operated and enables only the external VTR to be controlled by the VTR START button of the unit or the VTR button of the lens

- **26P CONTROL ON**

- See "Selecting Functions" (page 65) for a description of FUNCTION 3/5 page operations

Switching from the internal VTR to the external VTR

If the internal VTR experiences problems (tapes becoming tangled, condensation, etc.) during operation and becomes unable to operate, the VTR START button of the unit and the VTR button of the lens will not function. In these cases, setting the 26P CONTROL function as noted above at the FUNCTION 3/5 page allows the external VTR to be operated in place of the internal VTR using the VTR START button of the unit or the VTR button of the lens.

Starting recording

Operate the external VTR to set it to recording paused status and press the VTR START button of the unit or the VTR button of the lens. The external VTR starts recording. Pressing the button again sets the VTR to the recording paused status.

Output level of the 26-pin output adaptor

When the unit is shipped from the factory, the audio level is set to -60 dBu balanced and the component video level is set to Sony level (see page 98). The audio level can be set to -20 dBu unbalanced and the component video level to MII level with an internal switch. Consult your dealer for a detailed description.

RET button

The images recorded on the VTR or return video signal which has been input to the VIDEO IN connector can be seen on the viewfinder screen when the RET (return video) button is pressed or while it is kept pressed in

What is displayed on the viewfinder screen changes as indicated in the table below according to the RET VIDEO switch setting and VTR mode

<Note>

When the REC SIGNAL item is set to VIDEO (when recording external input) at the MAIN FUNCTION page of the setting menu, the external input appears on the viewfinder screen. However, the camera image appears on the viewfinder screen while the RET button is held down

■ Lens RET button functions

| RET VIDEO switch setting | Internal VTR mode | Description of what appears on viewfinder screen |
|--------------------------|-------------------|---|
| INT | Recording | Images shot by camera RET button does not function |
| | Recording paused | What has been recorded (2-second rec review) can be checked |
| | Playing | Internal VTR's playback images RET button does not function |
| | Playback paused | Search operation for successive shooting |
| EXT | Recording | Return video signal which has been supplied to VIDEO IN connector |
| | Recording paused | Return video signal which has been supplied to VIDEO IN connector |
| | Playing | Return video signal which has been supplied to VIDEO IN connector |
| | Playback paused | Return video signal which has been supplied to VIDEO IN connector |

Replacing the Backup Battery

The unit is shipped from the factory with a backup battery already mounted. When the battery runs out, the TCG time code value indicates 00 00 00 00. At this time, the time code value cannot be backed up. In addition, the "BACK UP BATT EMPTY" display appears in the viewfinder for 3 seconds when the POWER switch is set to ON to indicate that the battery must be replaced. Consult your dealer when replacing the battery.

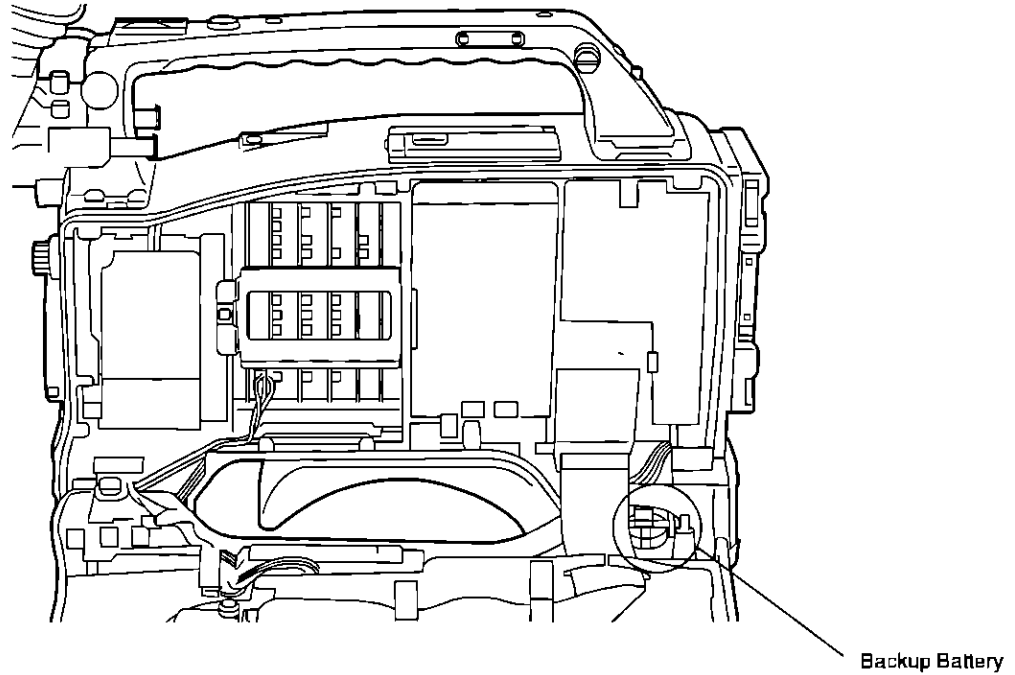

Setting Menu Screens

MARKER Screen

This page sets the setting for the marker displays inside the viewfinder

| |
|--------------------|
| - MARKER - |
| -CENTER MARK ON |
| SAFETY ZONE 1 |

| Item | Variable range | VF display | Remarks |
|-------------|-------------------|-------------|-----------------------------------|
| CENTER MARK | <u>ON</u> OFF | USER ENG | Center mark display ON/OFF |
| SAFETY ZONE | OFF <u>1-6</u> | USER ENG | Safety zone switching/display OFF |

The underlined setting in the Variable range column indicates the preset mode

Menu screen display methods

USER menu Setting the MENU switch to SET displays the USER menu

ENG menu Holding down the SHIFT/ITEM and UP buttons simultaneously and setting the MENU switch to SET displays the ENG menu

VF DISPLAY Screen

This page sets the setting for the display information inside the viewfinder

| | |
|----------------|------|
| - VF DISPLAY - | |
| -DISP MODE | 3 |
| EXTENDER | ON |
| SHUTTER | ON |
| TAPE | ON |
| BATTERY | ON |
| FILTER | ON |
| WHITE | ON |
| GAIN | ON |
| LEVEL METER | ON |
| IRIS | IRIS |
| CAMERA ID | ON |

Menu screen display methods

USER menu Setting the MENU switch to SET displays the USER menu

ENG menu Holding down the SHIFT/ITEM and UP buttons simultaneously and setting the MENU switch to SET displays the ENG menu

| Item | Variable range | VF display | Remarks | | | |
|-------------|-----------------------------------|-------------|--|--|---|---|
| | | | Change | Display | | |
| | | | | 1 | 2 | 3 |
| DISP MODE | 1- <u>3</u> | USER ENG | FILTER | × | × | ○ |
| | | | GAIN | × | × | ○ |
| | | | AWB | × | × | ○ |
| | | | AUTO KNEE SW | × | ○ | ○ |
| | | | SHUTTER | × | ○ | ○ |
| | | | ABB STATUS | × | ○ | ○ |
| | | | AWB STATUS | × | ○ | ○ |
| | | | | | | |
| EXTENDER | <u>ON</u> OFF | USER ENG | Extender display ON/OFF | | | |
| SHUTTER | <u>ON</u> OFF | USER ENG | Shutter speed display ON/OFF | | | |
| TAPE | <u>ON</u> OFF | USER ENG | Remaining tape length display ON/OFF | | | |
| BATTERY | <u>ON</u> OFF | USER ENG | Battery voltage display ON/OFF | | | |
| FILTER | <u>ON</u> OFF | USER ENG | Filter No display ON/OFF | | | |
| WHITE | <u>ON</u> OFF | USER ENG | AWB PRE/A/B display ON/OFF | | | |
| GAIN | <u>ON</u> OFF | USER ENG | Currently selected gain display ON/OFF | | | |
| LEVEL METER | <u>ON</u> OFF | USER ENG | Audio level meter display ON/OFF | | | |
| IRIS | <u>IRIS</u> S+IRIS S OFF | USER ENG | IRIS | Only the f-number is displayed | | |
| | | | S+IRIS | Both the super iris ON status and f-number are displayed | | |
| | | | S | Only the super iris ON status is displayed | | |
| | | | OFF | Neither the super iris ON status nor f-number is displayed | | |
| CAMERA ID | <u>ON</u> OFF | USER ENG | Mix ON/OFF during color bar recording | | | |

The underlined setting in the Variable range column indicates the preset mode

Setting Menu Screens

CAMERA ID Screen

This page performs the camera ID settings. Each time the UP button is pressed, the character display changes in the order of space, English letters (A to Z), numbers (0 to 9) and symbols [space, >, <,), (, ', ', ,, --, -, ~, /, !]. Pressing the DOWN button changes the character display in the reverse order.

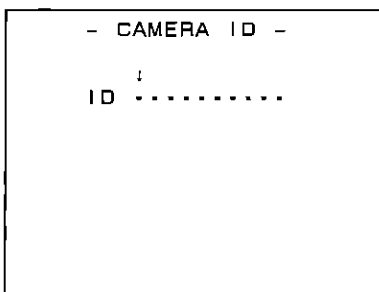

| Item | Variable range | VF display | Remarks |
|----------|----------------|-------------|-----------------|
| ID | — | USER ENG | Camera ID input |

SHUTTER SPEED Screen

This page performs the shutter speed settings. The ON/OFF status for each item is indicated by displaying an asterisk (*) or period (.) in front of the item on the screen.

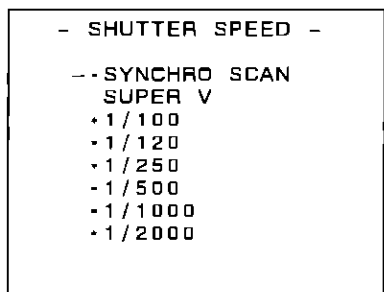

| Item | Variable range | VF display | Remarks |
|--------------|------------------|------------|-------------------------------------|
| SYNCHRO SCAN | <u>ON</u> OFF | ENG | Synchro scan shutter speed setting |
| SUPER V | <u>ON</u> OFF | ENG | SUPER V mode setting |
| 1/100 | <u>ON</u> OFF | ENG | Shutter speed 1/100 setting ON/OFF |
| 1/120 | <u>ON</u> OFF | ENG | Shutter speed 1/120 setting ON/OFF |
| 1/250 | <u>ON</u> OFF | ENG | Shutter speed 1/250 setting ON/OFF |
| 1/500 | <u>ON</u> OFF | ENG | Shutter speed 1/500 setting ON/OFF |
| 1/1000 | <u>ON</u> OFF | ENG | Shutter speed 1/1000 setting ON/OFF |
| 1/2000 | <u>ON</u> OFF | ENG | Shutter speed 1/2000 setting ON/OFF |

The underlined setting in the Variable range column indicates the preset mode.

Menu screen display methods

USER menu Setting the MENU switch to SET displays the USER menu.

ENG menu Holding down the SHIFT/ITEM and UP buttons simultaneously and setting the MENU switch to SET displays the ENG menu.

SYNCHRO SCAN Screen

This page performs the synchro scan settings

| |
|------------------|
| - SYNCHRO SCAN - |
| 1/61 7 |

| Item | Variable range | VF display | Remarks |
|--------------|----------------------------------|-------------|---------------------------------|
| SYNCHRO SCAN | 1/30 4 <u>1/61 7</u> 1/250 | USER ENG | Synchro shutter speed selection |

! LED Screen

This page sets the ON/OFF setting for the ! LED display inside the viewfinder. The ON/OFF status for each item is indicated by displaying an asterisk (*) or period (.) in front of the item on the screen.

| |
|-----------------|
| - ! LED - |
| - * GAIN (0 dB) |
| GAIN (-3 dB) |
| - SHUTTER |
| WHITE PRESET |
| - EXTENDER |
| FILTER |
| SUPER V |

- ON
 OFF

| Item | Variable range | VF display | Remarks |
|--------------|------------------|------------|--|
| GAIN (0 dB) | <u>ON</u> OFF | ENG | This selects whether or not the LED is lighted when the gain is any value other than 0 dB |
| GAIN (-3 dB) | <u>ON</u> OFF | ENG | This selects whether or not the LED is lighted when the gain is any value other than -3 dB |
| SHUTTER | <u>ON</u> OFF | ENG | This selects whether or not the LED is lighted when the shutter is ON |
| WHITE PRESET | <u>ON</u> OFF | ENG | This selects whether or not the LED is lighted when the AWB CH is PRESET |
| EXTENDER | <u>ON</u> OFF | ENG | This selects whether or not the LED is lighted when the lens is in EXTENDER mode |
| FILTER | <u>ON</u> OFF | ENG | This selects whether or not the LED is lighted when the filter is any value other than 3200K |
| SUPER V | <u>ON</u> OFF | ENG | This selects whether or not the LED is lighted when SUPER V is ON |

<Note>

The ! LED lights when both GAIN (0 dB) and GAIN (-3 dB) are ON unless the gain is set to -3 dB or 0 dB

The underlined setting in the Variable range column indicates the preset mode

Menu screen display methods

USER menu Setting the MENU switch to SET displays the USER menu

ENG menu Holding down the SHIFT/ITEM and UP buttons simultaneously and setting the MENU switch to SET displays the ENG menu

Setting Menu Screens

SET UP CARD Screen

This page sets the loading, saving and formatting operations for setup cards. Align the "-" with the desired item and press the UP or DOWN button to perform the corresponding processing.

| | |
|-----------------|----|
| - SET UP CARD - | |
| -READ (-CAM) | |
| WRITE (-CARD) | |
| CARD CONFIG | |
| ID READ/WRITE | ON |

| Item | Variable range | VF display | Remarks |
|---------------|----------------|-------------|---|
| READ (→CAM) | — | USER ENG | Setup card data is written to the unit |
| WRITE (→CARD) | — | USER ENG | Camera data is written to the setup card |
| CARD CONFIG | — | USER ENG | The setup card is formatted |
| ID READ/WRITE | ON OFF | USER ENG | CAMERA ID READ/WRITE ON/OFF when reading from, or writing to the SET UP CARD* ON Enables READ/WRITE OFF Prevents READ/WRITE |

*For example, so as not to change the CAMERA ID when reading from, or writing to the SET UP CARD, the ID READ/WRITE should be selected to OFF.

MAIN FUNCTION Screen

This page performs the adjustment function settings.

| | |
|-------------------|-----|
| - MAIN FUNCTION - | |
| -REC SIGNAL | CAM |
| PHANTOM FRONT | ON |
| PHANTOM CH1 | OFF |
| PHANTOM CH2 | OFF |

| Item | Variable range | VF display | Remarks |
|---------------|----------------|------------|--|
| REC SIGNAL | CAM VIDEO | ENG | Switching for the Video input signal to be recorded CAM Camera input VIDEO Input from the VIDEO IN connector |
| PHANTOM FRONT | ON OFF | ENG | Phantom microphone (front) usage selection ON Phantom microphone (+48 V) used OFF Normal microphone used |
| PHANTOM CH1 | ON OFF | ENG | Phantom microphone (CH1) usage selection ON Phantom microphone (+48 V) used OFF Normal microphone used |
| PHANTOM CH2 | ON OFF | ENG | Phantom microphone (CH2) usage selection ON Phantom microphone (+48 V) used OFF Normal microphone used |

BATT/TAPE ALARM Screen

The battery end and tape end audio warnings during shooting can be switched off if they become undesirable.

| | |
|---------------------|----|
| - BATT/TAPE ALARM - | |
| -BATT NEAR END | ON |
| BATT END | ON |
| TAPE NEAR END | ON |
| TAPE END | ON |

| Item | Variable range | VF display | Remarks |
|---------------|----------------|------------|------------------------------------|
| BATT NEAR END | ON OFF | ENG | Battery near end audio ON/OFF |
| BATT END | ON OFF | ENG | Battery end audio warning ON/OFF |
| TAPE NEAR END | ON OFF | ENG | Tape near end audio warning ON/OFF |
| TAPE END | ON OFF | ENG | Tape end audio warning ON/OFF |

FUNCTION 1/5 Screen

This page performs the adjustment function 1 settings. The ON/OFF status for each item is indicated by displaying an asterisk (*) or period (.) in front of the item on the screen.

| | |
|------------------|---------------|
| - FUNCTION 1/5 - | |
| - | DETAIL |
| | 2D LPF |
| | SKIN TONE DTL |
| | MATRIX |
| - | GAMMA |
| | TEST SAW |
| - | FLARE |

- ON
OFF

| Item | Variable range | VF display | Remarks |
|---------------|------------------|------------|--|
| DETAIL | <u>ON</u> OFF | ENG | Detail (H, V) ON/OFF switching |
| 2D LPF | ON <u>OFF</u> | ENG | ON/OFF switching for 2-dimensional LPF (Low Pass Filter) which reduces color smear |
| SKIN TONE DTL | ON <u>OFF</u> | ENG | Skin tone detail ON/OFF switching |
| MATRIX | <u>ON</u> OFF | ENG | Color adjustment ON/OFF switching |
| GAMMA | <u>ON</u> OFF | ENG | Gamma circuit ON/OFF switching |
| TEST SAW | ON <u>OFF</u> | ENG | Test signal ON/OFF switching |
| FLARE | <u>ON</u> OFF | ENG | Flare compensation ON/OFF switching |

FUNCTION 2/5 Screen

This page performs the adjustment function 2 settings.

| | | |
|------------------|---------------|--------|
| - FUNCTION 2/5 - | | |
| - | SUPER V | FRM1 |
| | FILTER INH | OFF |
| | SHOCKLESS AWB | NORMAL |
| | S IRIS SW | S IRIS |
| | S SCAN SEL | OFF |

| Item | Variable range | VF display | Remarks |
|---------------|--------------------------------------|------------|---|
| SUPER V | OFF <u>FRM1</u> FRM2 | ENG | Super V ON/OFF switching FRM1 Normal mode FRM2 Lag reduction mode |
| FILTER INH | ON <u>OFF</u> | ENG | Switch that determines whether AWB memory (Ach, Bch) data is stored for each filter ON Ach and Bch memory only (2 memory units), regardless of the filter OFF Data is stored for each filter (4×2=8 memory units) |
| SHOCKLESS AWB | OFF <u>NORMAL</u> SLOW FAST | ENG | Shockless AWB ON (NORMAL/SLOW/FAST)/OFF switching |
| S IRIS SW | <u>S IRIS</u> 30 dB | ENG | Super iris (S IRIS)/30 dB switching |
| S SCAN SEL | ON <u>OFF</u> | ENG | Synchro scan ON/OFF switching ON S SCAN speed can be varied by the SUPER IRIS/MODE CHECK switch OFF Normal mode |

The underlined setting in the Variable range column indicates the preset mode.

Menu screen display methods

USER menu Setting the MENU switch to SET displays the USER menu.

ENG menu Holding down the SHIFT/ITEM and UP buttons simultaneously and setting the MENU switch to SET displays the ENG menu.

Setting Menu Screens

FUNCTION 3/5 Screen

This page performs the adjustment function 3 settings

| | |
|------------------|---------|
| - FUNCTION 3/5 - | |
| -HUMID OPE | OFF |
| 26P CONTROL | OFF |
| REC START | NORMAL |
| TC MODE | DF |
| UB MODE | USER |
| PAUSE TIMER | 30 |
| BATTERY SEL | NiCd-12 |
| TCG VF DISP | OFF |

| Item | Variable range | VF display | Remarks |
|-------------|---|------------|--|
| HUMID OPE | ON <u>OFF</u> | ENG | VTR operation selection when condensation occurs ON Operation continues normally OFF All operations prohibited except for POWER switch and EJECT button |
| 26P CONTROL | <u>OFF</u> BOTH ON | ENG | 26P remote control selection OFF Unit only (26P control does not function) BOTH Unit and 26P remote control (TALLY LED indicates unit REC status) ON 26P remote control only (TALLY LED indicates 26P VTR REC status) |
| REC START | ALL <u>NORMAL</u> | ENG | REC acceptance selection for VTR START/STOP ALL REC accepted regardless of VTR mode NORMAL REC accepted only during STOP (POWER SAVE) mode and REC PAUSE mode |
| TC MODE | <u>DF</u> NDF | ENG | Time code DF/NDF switching DF Drop frame mode NDF Non-drop frame mode |
| UB MODE | <u>USER</u> REAL EXT | ENG | LTC UB usage method selection USER User setting (fixed value) REAL Real-time operation according to the TIME DATE time EXT When there is external TC input the UBG value is slave locked (When there is no external input, the user setting is used) |
| PAUSE TIMER | 10 20 <u>30</u> | ENG | Selection for the recording/pause hold time 10 10 minutes 20 20 minutes 30 30 minutes |
| BATTERY SEL | <u>NiCd-12</u> NiCd-13 NiCd-14 DIGITAL | ENG | Battery lype selection* NiCd-12 12 V Nicad battery NiCd-13 13 V Nicad battery NiCd-14 14 V Nicad battery DIGITAL Digital battery |
| TCG VF DISP | ON <u>OFF</u> | ENG | Viewfinder time code display ON/OFF ON Time code is displayed OFF Time code is not displayed |

*Even if the BATTERY SEL is selected to NiCd-12, 13 or 14, the camera automatically senses whether or not an Anton Bauer's Intelligent Battery is fitted. In the case of an intelligent battery, a numerical indication (percentage) of power available is displayed in the viewfinder. If the camera is usually used with an intelligent battery, BATTERY SEL should be set to DIGITAL.

FUNCTION 4/5 Screen

This page performs the adjustment function 4 settings

| | |
|------------------|--------|
| - FUNCTION 4/5 - | |
| -FRONT MIC | -40dB |
| REAR MIC CH1 | -60dB |
| REAR MIC CH2 | -60dB |
| LINE CH1/CH2 | +4dB |
| REAR AUDIO | STEREO |
| MIC LOWCUT CH1 | OFF |
| MIC LOWCUT CH2 | OFF |
| EMPHASIS | OFF |
| CUE AUDIO | CH1 |

| Item | Variable range | VF display | Remarks |
|----------------|-------------------------------|------------|---|
| FRONT MIC | -40/ -50/ <u>-60</u> dB | ENG | Camera microphone input level selection |
| REAR MIC CH1 | -40/ -50/ <u>-60</u> dB | ENG | Rear jack AUDIO CH1 input microphone level selection |
| REAR MIC CH2 | -40/ -50/ <u>-60</u> dB | ENG | Rear jack AUDIO CH2 input microphone level selection |
| LINE CH1/CH2 | <u>+4</u> 0/ -6 dB | ENG | Rear jack AUDIO CH1/CH2 input line input level selection |
| REAR AUDIO | <u>STEREO</u> MONO | ENG | Audio CH1/CH2 rear jack input selection STEREO Selects stereo input (CH1 input is recorded in CH1 and CH2 input is recorded in CH2) MONO Selects monaural input (The signals of CH1 and CH2 are mixed and recorded in CH1 and CH2 respectively) |
| MIC LOWCUT CH1 | ON <u>OFF</u> | ENG | CH1 microphone bypass filter ON/OFF switching |
| MIC LOWCUT CH2 | ON <u>OFF</u> | ENG | CH2 microphone bypass filter ON/OFF switching |
| EMPHASIS | ON <u>OFF</u> | ENG | Emphasis ON/OFF switching |
| CUE AUDIO | CH1 CH2 <u>MIX</u> | ENG | CUE AUDIO recording setting CH1 Records CH1 AUDIO CH2 Records CH2 AUDIO MIX Records CH1 and CH2 mixed AUDIO |

The underlined setting in the Variable range column indicates the preset mode

Menu screen display methods

USER menu Setting the MENU switch to SET displays the USER menu

ENG menu Holding down the SHIFT/ITEM and UP buttons simultaneously and setting the MENU switch to SET displays the ENG menu

Setting Menu Screens

FUNCTION 5/5 Screen

This page performs the adjustment function 5 settings

| | |
|------------------|-----|
| - FUNCTION 5/5 - | |
| -AUDIO OUT | CH1 |
| LIMITER | ON |
| TEST TONE | ON |

| Item | Variable range | VF display | Remarks |
|-----------|-----------------------------|------------|--|
| AUDIO OUT | <u>CH1</u> / CH2/ MIX | ENG | AUDIO OUT selection CH1 CH1 output to AUDIO OUT CH2 CH2 output to AUDIO OUT MIX CH1 and CH2 mixed and output to AUDIO OUT |
| LIMITER | <u>ON</u> OFF | ENG | Audio limiter ON/OFF switching ON Limiter ON OFF Limiter OFF |
| TEST TONE | <u>ON</u> OFF | ENG | Audio test tone ON/OFF switching during color bar output |

TIME DATE Screen

This page performs the date and time settings. After the date and time have been changed, pressing the UP or DOWN buttons executes the settings.

| | |
|-----------------|----|
| - TIME/DATE - | |
| -YEAR | 95 |
| MONTH | 01 |
| DAY | 01 |
| HOUR | 00 |
| MINUTE | 00 |
| ■ TIME/DATE SET | |

| Item | Variable range | VF display | Remarks |
|---------------|-----------------|------------|------------------------|
| YEAR | <u>95</u> to 10 | ENG | Year setting |
| MONTH | <u>1</u> to 12 | ENG | Month setting |
| DAY | <u>1</u> to 31 | ENG | Day setting |
| HOUR | <u>0</u> to 23 | ENG | Hour setting |
| MINUTE | <u>0</u> to 59 | ENG | Minute setting |
| TIME/DATE SET | — | ENG | Date/time confirmation |

The underlined setting in the Variable range column indicates the preset mode.

Menu screen display methods

USER menu Setting the MENU switch to SET displays the USER menu

ENG menu Holding down the SHIFT/ITEM and UP buttons simultaneously and setting the MENU switch to SET displays the ENG menu

LOW SETTING Screen

This page sets the low level

| - LOW SETTING - | |
|-----------------|------|
| -MASTER GAIN | 0 dB |
| H DTL LEVEL | 08 |
| V DTL LEVEL | 10 |
| DTL CORING | 03 |
| H DTL FREQ | 04 |
| DARK DTL | 00 |
| LEVEL DEPEND | 01 |
| MASTER GAMMA | 0 45 |
| BLACK STRETCH | OFF |
| MATRIX TABLE | A |

| Item | Variable range | VF display | Remarks |
|---------------|-------------------------------|------------|---|
| MASTER GAIN | -3 dB <u>0</u> dB 30 dB | ENG | Gains of -3, 0, 3, 6, 9, 12, 15, 18, 21, 24 and 30 dB (S H GAIN) can be set |
| H DTL LEVEL | 0 <u>8</u> 31 | ENG | H DTL (detail) level setting |
| V DTL LEVEL | 0 <u>10</u> 31 | ENG | V DTL (detail) level setting |
| DTL CORING | 0 <u>3</u> 15 | ENG | DTL coring setting |
| H DTL FREQ | 1 <u>4</u> 5 | ENG | H DTL frequency selection |
| DARK DTL | <u>0</u> 5 | ENG | Dark detail setting |
| LEVEL DEPEND | 0 <u>1</u> 5 | ENG | LEVEL DEPEND setting |
| MASTER GAMMA | 0 35 <u>0 45</u> 0 75 | ENG | Master gamma setting 0 01 steps |
| BLACK STRETCH | ON <u>OFF</u> | ENG | ON/OFF switching for mode which compensates low-illumination black-out |
| MATRIX TABLE | <u>A</u> B | ENG | Color compensation table selection |

The underlined setting in the Variable range column indicates the preset mode

Menu screen display methods

USER menu Setting the MENU switch to SET displays the USER menu

ENG menu Holding down the SHIFT/ITEM and UP buttons simultaneously and setting the MENU switch to SET displays the ENG menu

Setting Menu Screens

MID SETTING Screen

This page sets the middle level

| | |
|-----------------|------|
| - MID SETTING - | |
| -MASTER GAIN | 9 dB |
| H DTL LEVEL | 08 |
| V DTL LEVEL | 10 |
| DTL CORING | 06 |
| H DTL FREQ | 04 |
| DARK DTL | 00 |
| LEVEL DEPEND | 03 |
| MASTER GAMMA | 0 45 |
| BLACK STRETCH | OFF |
| MATRIX TABLE | A |

| Item | Variable range | VF display | Remarks |
|---------------|-------------------------------|------------|---|
| MASTER GAIN | -3 dB <u>9</u> dB 30 dB | ENG | Gains of -3, 0, 3, 6, 9, 12, 15, 18, 21, 24 and 30 dB (S H GAIN) can be set |
| H DTL LEVEL | 0 <u>8</u> 31 | ENG | H DTL (detail) level setting |
| V DTL LEVEL | 0 <u>10</u> 31 | ENG | V DTL (detail) level setting |
| DTL CORING | 0 <u>5</u> 15 | ENG | DTL coring setting |
| H DTL FREQ | 1 <u>4</u> 5 | ENG | H DTL frequency selection |
| DARK DTL | <u>0</u> 5 | ENG | Dark detail setting |
| LEVEL DEPEND | 0 3 <u>5</u> | ENG | LEVEL DEPEND setting |
| MASTER GAMMA | 0 35 <u>0 45</u> 0 75 | ENG | Master gamma setting 0 01 steps |
| BLACK STRETCH | ON <u>OFF</u> | ENG | ON/OFF switching for mode which compensates low-illumination black-out |
| MATRIX TABLE | <u>A</u> B | ENG | Color compensation table selection |

The underlined setting in the Variable range column indicates the preset mode

Menu screen display methods

USER menu Setting the MENU switch to SET displays the USER menu

ENG menu Holding down the SHIFT/ITEM and UP buttons simultaneously and setting the MENU switch to SET displays the ENG menu

HIGH SETTING Screen

This page sets the high level

| - HIGH SETTING - | |
|------------------|-------|
| -MASTER GAIN | 18 dB |
| H DTL LEVEL | 08 |
| V DTL LEVEL | 05 |
| DTL CORING | 10 |
| H DTL FREQ | 04 |
| DARK DTL | 00 |
| LEVEL DEPEND | 05 |
| MASTER GAMMA | 0 55 |
| BLACK STRETCH | OFF |
| MATRIX TABLE | B |

| Item | Variable range | VF display | Remarks |
|---------------|--------------------------------|------------|---|
| MASTER GAIN | -3 dB <u>18</u> dB 30 dB | ENG | Gains of -3, 0, 3, 6, 9, 12, 15, 18, 21, 24 and 30 dB (S H GAIN) can be set |
| H DTL LEVEL | 0 8 31 | ENG | H DTL (detail) level setting |
| V DTL LEVEL | 0 <u>5</u> 31 | ENG | V DTL (detail) level setting |
| DTL CORING | 0 <u>10</u> 15 | ENG | DTL coring setting |
| H DTL FREQ | 1 <u>4</u> 5 | ENG | H DTL frequency selection |
| DARK DTL | <u>0</u> 5 | ENG | Dark detail setting |
| LEVEL DEPEND | 0 <u>5</u> | ENG | LEVEL DEPEND setting |
| MASTER GAMMA | 0 35 <u>0 55</u> 0 75 | ENG | Master gamma setting 0 01 steps |
| BLACK STRETCH | ON <u>OFF</u> | ENG | ON/OFF switching for mode which compensates low-illumination black-out |
| MATRIX TABLE | <u>A</u> B | ENG | Color compensation table selection |

The underlined setting in the Variable range column indicates the preset mode

Menu screen display methods

USER menu Setting the MENU switch to SET displays the USER menu

ENG menu Holding down the SHIFT/ITEM and UP buttons simultaneously and setting the MENU switch to SET displays the ENG menu

Setting Menu Screens

LEVEL 1/6 Screen

This page performs the camera setup level 1 settings

| | |
|---------------|-----|
| - LEVEL 1/6 - | |
| -C DTL COMPE | OFF |
| CHROMA DTL | 00 |
| C DTL CORING | 00 |
| KNEE APERTURE | ON |
| SLIM DTL | OFF |
| SUPER COLOR | ON |
| CORNER DTL | OFF |

| Item | Variable range | VF display | Remarks |
|---------------|------------------|------------|---|
| C DTL COMPE | ON <u>OFF</u> | ENG | Chroma DTL ON/OFF switching |
| CHROMA DTL | <u>0</u> 15 | ENG | Chroma DTL setting |
| C DTL CORING | <u>0</u> 15 | ENG | Chroma DTL CORING setting |
| KNEE APERTURE | ON <u>OFF</u> | ENG | Knee aperture ON/OFF switching |
| SLIM DTL | ON <u>OFF</u> | ENG | ON/OFF switching for mode which narrows detail |
| SUPER COLOR | ON <u>OFF</u> | ENG | ON/OFF switching for color dynamic range expansion |
| CORNER DTL | ON <u>OFF</u> | ENG | ON/OFF switching for mode which increases edge resolution |

LEVEL 2/6 Screen

This page performs the camera setup level 2 settings

| | |
|------------------|-----|
| - LEVEL 2/6 - | |
| -SKIN TONE HUE | 103 |
| SKIN TONE LEVEL | 25 |
| SKIN TONE WIDTH | 15 |
| SKIN TONE CORING | 15 |
| SKIN TONE ZEBRA | OFF |

| Item | Variable range | VF display | Remarks |
|------------------|----------------------|------------|----------------------------------|
| SKIN TONE HUE | <u>103</u> 143 | ENG | Skin tone hue setting |
| SKIN TONE LEVEL | 1 <u>25</u> 50 | ENG | Skin tone level setting |
| SKIN TONE WIDTH | 1 <u>15</u> 30 | ENG | Skin tone width setting |
| SKIN TONE CORING | 0 <u>15</u> | ENG | Skin tone coring setting |
| SKIN TONE ZEBRA | ON <u>OFF</u> | ENG | Skin tone zebra ON/OFF switching |

<Note>

Only numbers are displayed while the variable range of any item except SKIN TONE ZEBRA ON/OFF is being changed

The underlined setting in the Variable range column indicates the preset mode

Menu screen display methods

USER menu Setting the MENU switch to SET displays the USER menu

ENG menu Holding down the SHIFT/ITEM and UP buttons simultaneously and setting the MENU switch to SET displays the ENG menu

LEVEL 3/6 Screen

This page performs the camera setup level 3 settings

| - LEVEL 3/6 - | |
|------------------|------|
| -M PED | +000 |
| SET UP | 7.5% |
| MANUAL KNEE | ON |
| KNEE POINT | 197 |
| KNEE SLOPE | 12 |
| WHITE CLIP | ON |
| WHITE CLIP LEVEL | 254 |

| Item | Variable range | VF display | Remarks |
|------------------|-----------------------------|------------|--|
| M PED | -128 <u>+000</u> +127 | ENG | M PED (Master pedestal level) setting |
| SET UP | <u>7.5%</u> 0% | ENG | Setup level switching |
| MANUAL KNEE | <u>ON</u> OFF | ENG | Mode setting when AUTO KNEE switch is set to OFF |
| KNEE POINT | <u>197</u> 219 | ENG | Manual knee point position setting |
| KNEE SLOPE | 0 <u>12</u> 25 | ENG | Manual knee inclination setting |
| WHITE CLIP | <u>ON</u> OFF | | White clip ON/OFF switching |
| WHITE CLIP LEVEL | 238 <u>254</u> | | White clip level setting |

The underlined setting in the Variable range column indicates the preset mode

Menu screen display methods

USER menu Setting the MENU switch to SET displays the USER menu

ENG menu Holding down the SHIFT/ITEM and UP buttons simultaneously and setting the MENU switch to SET displays the ENG menu

Setting Menu Screens

LEVEL 4/6 Screen

This page performs the camera setup level 4 settings

| | |
|---------------|-----|
| - LEVEL 4/6 - | |
| -R FLARE | --- |
| G FLARE | --- |
| B FLARE | --- |
| R GAMMA | +00 |
| B GAMMA | +00 |

| Item | Variable range | VF display | Remarks |
|---------|--------------------------|------------|---|
| R FLARE | 00 100 | ENG | Rch flare setting The preset value differs according to the camera |
| G FLARE | 00 100 | ENG | Gch flare setting The preset value differs according to the camera |
| B FLARE | 00 100 | ENG | Bch flare setting The preset value differs according to the camera |
| R GAMMA | -15 <u>+00</u> +15 | ENG | Rch gamma compensation value for the master gamma |
| B GAMMA | -15 <u>+00</u> +15 | ENG | Bch gamma compensation value for the master gamma |

The underlined setting in the Variable range column indicates the preset mode

Menu screen display methods

USER menu Setting the MENU switch to SET displays the USER menu

ENG menu Holding down the SHIFT/ITEM and UP buttons simultaneously and setting the MENU switch to SET displays the ENG menu

LEVEL 5/6 Screen

This page performs the recording level 5 settings

| | | |
|---------------|---|-----|
| - LEVEL 5/6 - | | |
| -MATRIX TABLE | A | |
| MATRIX R-G | | +10 |
| MATRIX R-B | | +10 |
| MATRIX G-R | | +10 |
| MATRIX G-B | | +10 |
| MATRIX B-R | | +10 |
| MATRIX B-G | | +10 |

| Item | Variable range | VF display | Remarks |
|--------------|--------------------------|------------|----------------------------------|
| MATRIX TABLE | <u>A</u> B | ENG | Color adjustment table selection |
| MATRIX R-G | -25 <u>+10</u> +25 | ENG | Color adjustment |
| MATRIX R-B | -25 <u>+10</u> +25 | ENG | Color adjustment |
| MATRIX G-R | -25 <u>+10</u> +25 | ENG | Color adjustment |
| MATRIX G-B | -25 <u>+10</u> +25 | ENG | Color adjustment |
| MATRIX B-R | -25 <u>+10</u> +25 | ENG | Color adjustment |
| MATRIX B-G | -25 <u>+10</u> +25 | ENG | Color adjustment |

The underlined setting in the Variable range column indicates the preset mode

<Note>

All settings are "00" for the preset mode of MATRIX TABLE B

Menu screen display methods

USER menu Setting the MENU switch to SET displays the USER menu

ENG menu Holding down the SHIFT/ITEM and UP buttons simultaneously and setting the MENU switch to SET displays the ENG menu

Setting Menu Screens

LEVEL 6/6 Screen

This page performs the camera setup level 6 settings

| - LEVEL 6/6 - | |
|-----------------|-----|
| -H PHASE COARSE | 07 |
| H PHASE FINE | 128 |
| SC PHASE COARSE | 0 |
| SC PHASE FINE | 128 |
| A IRIS LEVEL | 62 |
| A IRIS PEAK/AVE | 60 |
| A IRIS MODE | NOR |
| S IRIS LEVEL | 75 |

| Item | Variable range | VF display | Remarks |
|-----------------|-------------------------|------------|---|
| H PHASE COARSE | 0 <u>7</u> 15 | ENG | H phase rough adjustment during GENLOCK mode |
| H PHASE FINE | 0 <u>128</u> 255 | ENG | H phase fine adjustment during GENLOCK mode |
| SC PHASE COARSE | <u>0</u> 3 | ENG | SC phase rough adjustment during GENLOCK mode |
| SC PHASE FINE | 0 <u>128</u> 255 | ENG | SC phase fine adjustment during GENLOCK mode |
| A IRIS LEVEL | 0 <u>62</u> 100 | ENG | Auto iris target value setting |
| A IRIS PEAK/AVE | 0 <u>60</u> 100 | ENG | Auto iris peak average value ratio setting |
| A IRIS MODE | <u>NORMAL</u> CENTER | ENG | Auto iris mode selection |
| S IRIS LEVEL | 0 <u>75</u> 100 | ENG | Super iris target value setting (Backlight compensation mode) |

The underlined setting in the Variable range column indicates the preset mode

Menu screen display methods

USER menu Setting the MENU switch to SET displays the USER menu

ENG menu Holding down the SHIFT/ITEM and UP buttons simultaneously and setting the MENU switch to SET displays the ENG menu

VF OPERATION Screen

This page performs the viewfinder display settings

| | |
|------------------|------|
| - VF OPERATION - | |
| -VF OUT | Y |
| VF DTL | 2 |
| ZEBRA1 DETECT | 070 |
| ZEBRA2 DETECT | 085 |
| ZEBRA2 | SPOT |

| Item | Variable range | VF display | Remarks |
|---------------|--------------------------------|------------|--|
| VF OUT | <u>Y</u> NAM R G B | ENG | VF OUT selection |
| VF DTL | 0 <u>2</u> 4 | ENG | VF DTL selection |
| ZEBRA1 DETECT | 50 <u>70</u> 110 | ENG | ZEBRA1 DETECT level (IRE value) selling |
| ZEBRA2 DETECT | 50 <u>85</u> 110 | ENG | ZEBRA2 DETECT level (IRE value) selling |
| ZEBRA2 | ON OFF <u>SPOT</u> | ENG | ZEBRA2 ON/OFF switching and SPOT selection *When ZEBRA2 is set to SPOT, set the ZEBRA2 DETECT value higher than the ZEBRA1 DETECT value. If the ZEBRA2 DETECT value is less than the ZEBRA1 DETECT value, the ZEBRA pattern will not be displayed |

The underlined setting in the Variable range column indicates the preset mode

Menu screen display methods

USER menu Setting the MENU switch to SET displays the USER menu

ENG menu Holding down the SHIFT/ITEM and UP buttons simultaneously and setting the MENU switch to SET displays the ENG menu

Setting Menu Screens

LENS ADJ Screen

This page performs the lens adjustments. The ON/OFF status for each item is indicated by displaying an asterix (*) or period (.) in front of the item on the screen.

| |
|--|
| - LENS ADJ - -- F2.8 ADJ F16 ADJ |
|--|

- ON
OFF

| Item | Variable range | VF display | Remarks |
|----------|----------------|------------|--|
| F2.8 ADJ | — | ENG | Voltage is output only when selected by the cursor (arrow) |
| F16 ADJ | — | ENG | Voltage is output only when selected by the cursor (arrow) |

<Note>

When using a lens which allows the lens iris open or close end to be adjusted, set either "F2.8 ADJ" or "F16 ADJ" to ON and repeatedly adjust the lens iris until it is "F2.8" or "F16", respectively (Fujinon S18x6.7 BRM4/BERM4 lenses do not have this adjustment function)

MENU SELECT 1/3 Screen

This page performs the menu page display ON/OFF settings. The ON/OFF status for each item is indicated by displaying an asterix (*) or period (.) in front of the item on the screen.

| |
|---|
| - MENU SELECT 1/3 - -- MARKER - VF DISPLAY - CAMERA ID SHUTTER SPEED - SYNCHRO SCAN ILED - SET UP CARD - MAIN FUNCTION BATT/TAPE ALARM |
|---|

- ON
OFF

| Item | Variable range | VF display | Remarks |
|-----------------|------------------|------------|---|
| MARKER | <u>ON</u> OFF | ENG | MARKER item user menu display ON/OFF |
| VF DISPLAY | <u>ON</u> OFF | ENG | VF DISPLAY item user menu display ON/OFF |
| CAMERA ID | <u>ON</u> OFF | ENG | CAMERA ID item user menu display ON/OFF |
| SHUTTER SPEED | ON <u>OFF</u> | ENG | SHUTTER SPEED item user menu display ON/OFF |
| SYNCHRO SCAN | <u>ON</u> OFF | ENG | SYNCHRO SCAN item user menu display ON/OFF |
| ILED | ON <u>OFF</u> | ENG | ILED item user menu display ON/OFF |
| SET UP CARD | <u>ON</u> OFF | ENG | SET UP CARD item user menu display ON/OFF |
| MAIN FUNCTION | <u>ON</u> OFF | ENG | MAIN FUNCTION item user menu display ON/OFF |
| BATT/TAPE ALARM | ON <u>OFF</u> | ENG | BATT/TAPE ALARM item user menu display ON/OFF ON This switches the display ON OFF This switches the display OFF |

The underlined setting in the Variable range column indicates the preset mode

Menu screen display methods

USER menu Setting the MENU switch to SET displays the USER menu

ENG menu Holding down the SHIFT/ITEM and UP buttons simultaneously and setting the MENU switch to SET displays the ENG menu

MENU SELECT 2/3 Screen

This page performs the menu page display ON/OFF settings. The ON/OFF status for each item is indicated by displaying an asterisk (*) or period (.) in front of the item on the screen.

| |
|---------------------|
| - MENU SELECT 2/3 - |
| - FUNCTION 1/5 |
| FUNCTION 2/5 |
| FUNCTION 3/5 |
| FUNCTION 4/5 |
| FUNCTION 5/5 |
| TIME/DATE |
| LOW SETTING |
| MID SETTING |
| HIGH SETTING |

. ON
* OFF

| Item | Variable range | VF display | Remarks |
|--------------|------------------|------------|--|
| FUNCTION 1/5 | ON <u>OFF</u> | ENG | FUNCTION 1/5 item user menu display ON/OFF |
| FUNCTION 2/5 | ON <u>OFF</u> | ENG | FUNCTION 2/5 item user menu display ON/OFF |
| FUNCTION 3/5 | ON <u>OFF</u> | ENG | FUNCTION 3/5 item user menu display ON/OFF |
| FUNCTION 4/5 | ON <u>OFF</u> | ENG | FUNCTION 4/5 item user menu display ON/OFF |
| FUNCTION 5/5 | ON <u>OFF</u> | ENG | FUNCTION 5/5 item user menu display ON/OFF |
| TIME/DATE | ON <u>OFF</u> | ENG | TIME/DATE item user menu display ON/OFF |
| LOW SETTING | ON <u>OFF</u> | ENG | LOW SETTING item user menu display ON/OFF |
| MID SETTING | ON <u>OFF</u> | ENG | MID SETTING item user menu display ON/OFF |
| HIGH SETTING | ON <u>OFF</u> | ENG | HIGH SETTING item user menu display ON/OFF |

The underlined setting in the Variable range column indicates the preset mode.

Menu screen display methods

USER menu - Setting the MENU switch to SET displays the USER menu.

ENG menu - Holding down the SHIFT/ITEM and UP buttons simultaneously and setting the MENU switch to SET displays the ENG menu.

Setting Menu Screens

MENU SELECT 3/3 Screen

This page performs the menu page display ON/OFF settings. The ON/OFF status for each item is indicated by displaying an asterisk (*) or period (.) in front of the item on the screen.

| |
|---------------------|
| - MENU SELECT 3/3 - |
| - LEVEL 1/6 |
| LEVEL 2/6 |
| LEVEL 3/6 |
| LEVEL 4/6 |
| LEVEL 5/6 |
| LEVEL 6/6 |
| VF OPERATION |
| LENS ADJ |

- ON
OFF

| Item | Variable range | VF display | Remarks |
|--------------|------------------|------------|--|
| LEVEL 1/6 | ON <u>OFF</u> | ENG | LEVEL 1/6 item user menu display ON/OFF |
| LEVEL 2/6 | ON <u>OFF</u> | ENG | LEVEL 2/6 item user menu display ON/OFF |
| LEVEL 3/6 | ON <u>OFF</u> | ENG | LEVEL 3/6 item user menu display ON/OFF |
| LEVEL 4/6 | ON <u>OFF</u> | ENG | LEVEL 4/6 item user menu display ON/OFF |
| LEVEL 5/6 | ON <u>OFF</u> | ENG | LEVEL 5/6 item user menu display ON/OFF |
| LEVEL 6/6 | ON <u>OFF</u> | ENG | LEVEL 6/6 item user menu display ON/OFF |
| VF OPERATION | ON <u>OFF</u> | ENG | VF OPERATION item user menu display ON/OFF |
| LENS ADJ | ON <u>OFF</u> | ENG | LENS ADJ item user menu display ON/OFF |

The underlined setting in the Variable range column indicates the preset mode.

Menu screen display methods

USER menu Setting the MENU switch to SET displays the USER menu.

ENG menu Holding down the SHIFT/ITEM and UP buttons simultaneously and setting the MENU switch to SET displays the ENG menu.

AUTO SHADING Screen

This page performs the auto shading settings. Align the arrow with the desired BLACK or WHITE item and press the UP or DOWN button to execute the setting.

```

- AUTO SHADING -
-BLACK
WHITE (V SAW)
BLACK COMPE    ON
WHITE COMPE    ON
    
```

| Item | Variable range | VF display | Remarks |
|---------------|------------------|------------|--|
| BLACK | — | ENG | Auto black shading (digital) activated |
| WHITE (V SAW) | — | ENG | Auto white shading (V SAW) activated |
| BLACK COMPE | <u>ON</u> OFF | ENG | Black compensation ON/OFF |
| WHITE COMPE | <u>ON</u> OFF | ENG | White compensation ON/OFF |

The underlined setting in the Variable range column indicates the preset mode.

DATA RESET Screen

This page resets the menu display item settings. Aligning the cursor (arrow) with the item and pressing the UP or DOWN button resets the settings.

```

- DATA RESET -
-MENU INIT
    
```

| Item | Variable range | VF display | Remarks |
|------------|----------------|------------|--|
| DATA RESET | — | ENG | Sets the setting menu to the status when shipped from the factory. |

<Note>

The flare compensation value (LEVEL 4/6) and shading compensation value (AUTO SHADING) do not return to the default settings.

DIAGNOSTIC Screen

This page displays the unit's operating conditions and software version.

```

- DIAGNOSTIC -
OPERATION      00003  x10h
DRUM RUNNING   00000  x10h
THREADING      00010  x10
VTR SYSCON     Var<1 0>
CAM SYSCON     Var<1 0>
    
```

| Item | Variable range | VF display | Remarks |
|--------------|----------------|------------|----------------------------------|
| OPERATION | — | ENG | Operating time with the power ON |
| DRUM RUNNING | — | ENG | Drum rotating time |
| THREADING | — | — | Loading times |
| VTR SYSCON | — | ENG | Software version display |
| CAM SYSCON | — | ENG | Software version display |

Menu screen display methods

USER menu Setting the MENU switch to SET displays the USER menu.

ENG menu Holding down the SHIFT/ITEM and UP buttons simultaneously and setting the MENU switch to SET displays the ENG menu.

Warning System

If trouble is detected immediately after the power is turned on or during operation, the display window (LCD), WARNING lamp, lamps inside the viewfinder, and warning tones from the speaker and earphone inform the operator of trouble

| Item | Display window (LCD) | | | | Lamps | | Warning tone | Warning contents | VTR (section) operation | Countermeasures |
|-------|----------------------|------------------------|---------------------------------|-------------------------------|-------------------------------------|-------------------------------------|---|--|---|--|
| | Warning display | Warning display status | Remaining battery level display | Remaining tape length display | WARNING lamp | REC lamp | | | | |
| RF | RF | Lighted 1) | | | Flashes 4 times per second | Flashes 4 times per second | Emitted 4 times per second *1) | Video head clogging, recording system trouble | Head clogging is detected and a warning tone emitted Images may not be recorded properly | Clean the heads If images still cannot be recorded properly after the heads are cleaned, consult your dealer |
| SERVO | SERVO | Lighted | | | Flashes 4 times per second | Flashes 4 times per second | Emitted 4 times per second | The servo is out of order | Recording continues, but images may not be recorded properly | Turn off the power and consult your dealer (Lamps may flash briefly and then go off when tape running starts but this does not indicate trouble) |
| HUMID | HUMID | Lighted | | | Lighted | Flashes 4 times per second | Emitted 4 times per second *1) Continuous tone*2) | Condensation | Recording continues, but stops if tape sticking occurs Playback, fast forward and rewind operation stops | If tape running stops and the HUMID display does not go off even when the power is turned off and then on again, wait until the display goes off |
| SLACK | SLACK | Flashes | | | Flashes 4 times per second | Flashes 4 times per second | Continu- ous tone | Tape wind-up trouble | An error code appears in the time code display position of the display window (LCD) and the VTR stops | Check the error code in the display window (see page 126) and consult your dealer |

*1) During recording

*2) During playback fast forward or rewind

<Note>

If a cleaning tape is not available to deal with video head clogging, etc., first establish the STOP mode and then press the STOP button again while the RESET button on the side panel is kept depressed. While these buttons are held down, the cleaning roller will clean the heads for a maximum of 10 seconds.

| Item | Display window (LCD) | | | | Lamps | | Warning tone | Warning contents | VTR (section) operation | Countermeasures |
|-------------|----------------------|------------------------|---------------------------------|--|------------------------------|----------------------------|-------------------------------|--------------------------------|---|---|
| | Warning display | Warning display status | Remaining battery level display | Remaining tape length display | WARNING lamp | REC lamp | | | | |
| TAPE END | E TAPE F | Flashes *1) | | 1 of the 7 bars displayed, 5-0 display inside the viewfinder flashes | Flashes 1 time per second*1) | Flashes 1 time per second | Emitted 4 times per second | The tape is nearing its end | Operation continues | Replace the tape as necessary |
| | | Flashes | | All 7 bars displayed | Lighted | Flashes 4 times per second | Continuous tone | The tape has reached its end | Recording, playback or fast forward operation stops | Replace the cassette or rewind the tape |
| BATTERY END | E BATT F | Flashes | 1 of the 7 bars displayed | | Flashes 1 time per second | Flashes 1 time per second | Emitted 4 times per second*1) | The battery has almost run out | Operation continues | Replace the battery as necessary |
| | | Flashes | All 7 bars displayed | | Lighted | Flashes 4 times per second | Continuous tone | The battery has run out | Operation stops | Replace the battery |

*1) During recording

*2) During playback, fast forward or rewind

<Notes>

- When trouble occurs with the external VTR connected to the unit, warnings are displayed only by the unit's REC and TALLY lamps
- When connecting the external VTR to the 26-pin output adaptor and recording simultaneously with the internal and external VTRs, the REC and TALLY lamps flash if trouble occurs in either VTR. Check the warning displays of each VTR to confirm the error contents

Warning system priorities are as follows

- 1 SLACK
- 2 BATTERY END
- 3 TAPE END
- 4 BATTERY NEAR END
- 5 TAPE NEAR END
- 6 HUMID
- 7 SERVO
- 8 RF

Error Codes

When an error occurs in the unit for some reason or other, the following error codes appear in the display window

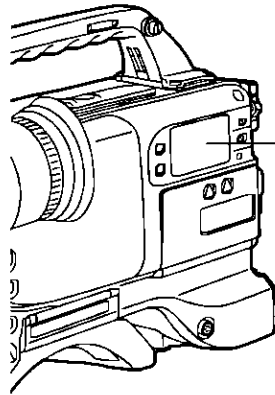

| Code No | Contents |
|---------|---------------------------|
| 8 | Solenoid trouble |
| 9 | The servo is not locked |
| A | Condensation has occurred |
| B | Supply reel trouble |
| C | Take-up reel trouble |
| D | Capstan trouble |
| E | Cylinder trouble |
| F | Loading trouble |

Maintenance

Condensation

If the unit is moved from a cold location to a warm location or used in areas with high humidity, the moisture in the air may adhere as water droplets on the head drum. This is called condensation, and if the tape is run under these conditions, it will easily stick to the drum. Therefore, the following points should be observed

- If the unit is moved under conditions where condensation may occur, eject the tape
- Before inserting the tape, set the POWER switch to ON and check that the HUMID display in the display window is not lighted. If the HUMID display is lighted, do not insert the tape until the display goes off

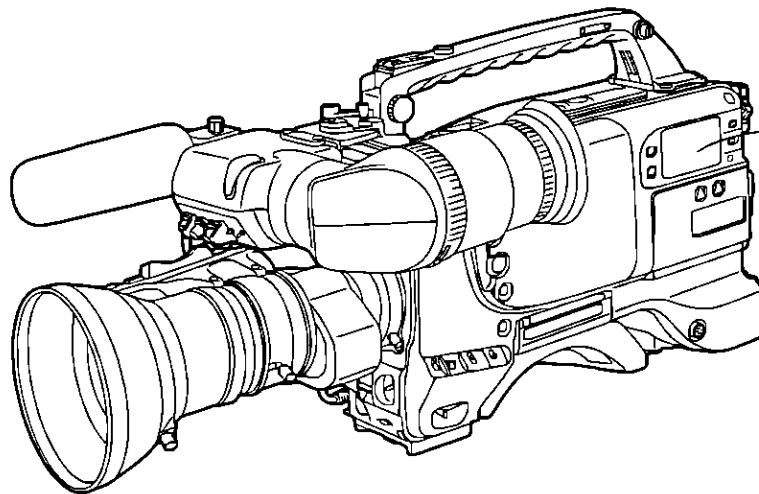

The HUMID display is not lighted

Cleaning the Heads

Use the AJ-CL12MP cleaning cassette when head cleaning is required. Improper use of the cleaning cassette may damage the video heads. Therefore, read the Handling Instructions for the cleaning tape carefully before use.

Cleaning the Viewfinder

- Do not use thinner or other solvents to remove dirt from the viewfinder.
- Wipe the lens with lens cleaner available on the market.
- Absolutely do not wipe the mirror. If dirt, etc. has adhered to the mirror, remove it using a air blower available on the market.

Characteristic Phenomenon of CCD Cameras

Smear

Smear occurs when shooting high-intensity subjects, and occurs more easily as the electronic shutter speed increases.

Inspections Before Shooting

Perform the following inspections before shooting to check that all systems are operating properly
Checking the image with a color monitor is recommended

Inspection preparations

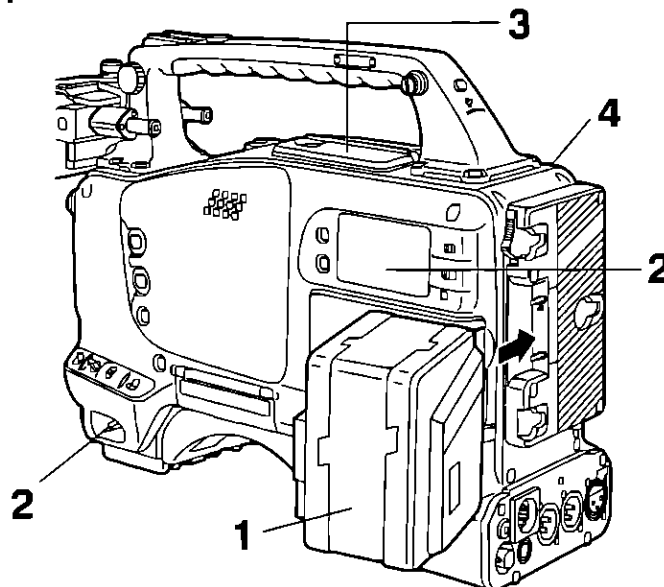

- 1** Insert a charged battery pack
- 2** Set the POWER switch to ON and check that the HUMID display does not appear and that five or more bars of the remaining battery level display are lighted
 - If the HUMID display appears, wait until the display goes off
 - If five or more bars of the remaining battery level display are not lighted, replace the battery pack with a sufficiently charged battery pack
- 3** Check that there are no cables, etc. around the cassette holder and top panel, and then press the EJECT button to open the cassette holder
- 4** Check the following items, and then insert a cassette and close the cassette holder
 - The cassette is not set to the write protect status
 - There is no slack in the tape

Inspections Before Shooting

Inspecting the camera section

Set the switches as follows

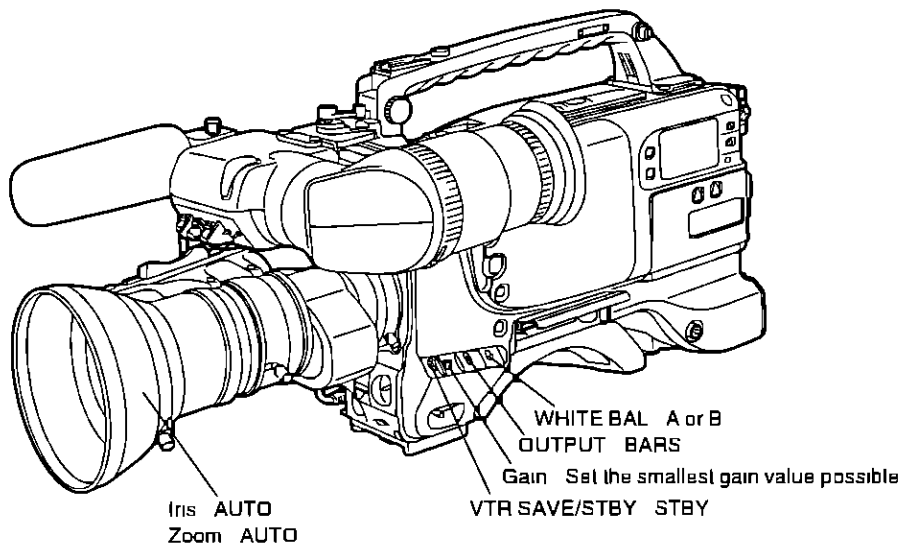

Inspecting the Viewfinder

- 1** Adjust the position of the viewfinder
- 2** Check that the color bar appears on the viewfinder screen, and then adjust the BRIGHT, CONTRAST and PEAKING controls so that the color bar appears clearly on the viewfinder
- 3** Check the following items
 - (1) Set the MENU SET/OFF switch to SET and check that the setting menu appears on the viewfinder screen
 - (2) Press the PAGE button and check that the setting menu page changes
 - (3) Press the SHIFT/ITEM switch and check that the cursor moves within the page
 - (4) Press the UP or DOWN button to check that the setting or ON/OFF display of the item selected with the cursor changes
- 4** Set the OUTPUT/AUTO KNEE switch to CAM and switch the FILTER knob to 1, 2, 3 and 4. Check that the number of the FILTER display on the viewfinder screen changes in accordance with the knob position
- 5** Perform the following operations to check that the (I) lamp lights when the items set to ON at the (I) LED page are operated
 - (1) Set the gain to any value other than 0 dB with the GAIN switch
 - (2) Set the SHUTTER switch to ON
 - (3) Set the WHITE BAL switch to PRST
 - (4) Insert the lens extender
 - (5) Set the FILTER knob to any position other than "1"
- 6** Press the SHUTTER switch repeatedly from the ON position to the SEL side and check that the shutter setting on the viewfinder screen changes
- 7** Aim the lens at an appropriate subject and turn the focus ring to bring the subject into focus. Check the image appearing in the viewfinder
- 8** Set both the AUDIO IN CH1 and CH2 switches to FRONT [MIC] and set LEVEL METER on the VF DISPLAY page of the setting menu to ON. Check that the audio level appears on the viewfinder screen when sound is input from the microphone connected to the MIC IN jack on the front panel. Then, check that the audio level disappears from the viewfinder screen when LEVEL METER on the VF DISPLAY page of the setting menu is set to OFF
- 9** Check that the zebra pattern appears on the viewfinder screen when the ZEBRA switch is set to ON, and disappears when the ZEBRA switch is set to OFF

<Note>

The items and functions in steps 3 to 6 may not be displayed or may not operate depending on the setting conditions. Set the unit to engineer mode, set DISPLAY MODE on the VF DISPLAY page of the setting menu to "3", and then set the required items at the SHUTTER SPEED, (I) LED and MENU SELECT 1/3 to 3/3 pages

Inspections Before Shooting

Inspecting the Iris and Zoom Functions

- 1 Set the zoom to electric zoom mode and check the electric zoom operation. Check that the image changes to telephoto and wide angle.
- 2 Set the zoom to manual zoom mode and check the manual zoom operation. Turn the manual zoom lever and check that the image changes to telephoto and wide angle.
- 3 Set the iris to automatic adjustment mode and aim the lens at subjects with differing brightness to check that the automatic iris adjustment functions.
- 4 Set the iris to manual adjustment mode and turn the iris ring to check the manual iris adjustment.
- 5 Hold down the instant iris automatic adjustment button and aim the lens at subjects with differing brightness to check the instant iris automatic adjustment performance.
- 6 Return the iris to automatic adjustment mode and change the GAIN switch setting to L, M and H to check the following items:
 - The iris is adjusted with respect to subjects with the same brightness in accordance with the switch setting.
 - The gain value display on the viewfinder screen changes in accordance with the switch setting.
- 7 When a lens with an extender is mounted, set the extender to the used position to check that the extender functions properly.

Perform "(1) Tape Running Inspections" to "(4) Earphone and Speaker Inspections" below consecutively.

(1) Tape Running Inspections

- 1 Set the VTR SAVE/STBY switch to SAVE and check that the VTR SAVE lamp inside the viewfinder lights.
- 2 Set the VTR SAVE/STBY switch to STBY and check that the VTR SAVE lamp goes off.
- 3 Set the F-RUN/R-RUN switch to R-RUN.
- 4 Set the DISPLAY switch to CTL.
- 5 Press the unit's VTR START button and check the following items:
 - The tape reels turn.
 - The counter display number changes.
 - The REC lamp inside the viewfinder lights.
 - The RF and SERVO lamps in the display window do not light.
- 6 Press the unit's VTR START button again. Check that the tape stops and the REC lamp inside the viewfinder goes off.
- 7 Check the same operations as in steps 5 and 6 using the VTR button of the lens.
- 8 Press the RESET button and check that the counter display number changes to "00 00 00 00".
- 9 Set the LIGHT switch to ON and check that the display window is illuminated.
- 10 Press the REW button and then press the PLAY button after the tape has rewound for a while. Check that the recording, playback and rewind operations are performed properly.
- 11 Press the FF button and check that fast forward operation is performed properly.

(2) Inspection of Audio Level Automatic Adjustment Functions

- 1 Set the AUDIO SELECT CH1/CH2 switch to AUTO
- 2 Set the AUDIO IN CH1/CH2 switch to FRONT [MIC]
- 3 Aim a microphone connected to the MIC IN jack at an appropriate sound source and check that the level display for both CH1 and CH2 changes in accordance with the sound level

(3) Inspection of Audio Level Manual Adjustment Functions

- 1 Set the AUDIO IN CH1/CH2 switch to FRONT [MIC]
- 2 Set the AUDIO SELECT CH1/CH2 switch to MAN
- 3 Turn the AUDIO LEVEL CH1/CH2 controls and check that the level display increases when the controls are turned to the right

(4) Earphone and Speaker Inspections

- 1 Set the VTR SAVE/STBY switch to STBY
- 2 Turn the MONITOR control and check that the speaker volume changes
- 3 Connect an earphone to the PHONES jack. Check that the sound to the speaker is cut off and that the microphone sound can be heard from the earphone
- 4 Turn the MONITOR control and check that the earphone volume changes

(5) Inspections when Using an External Microphone

- 1 Connect an external microphone to the AUDIO IN CH1 and CH2 connectors
- 2 Set the AUDIO IN CH1/CH2 switch to REAR [MIC]
- 3 Aim the microphone at a sound source and check that the audio level meter in the display window and the audio level display inside the viewfinder change in accordance with the sound level. Each channel can also be checked separately by connecting a single microphone to each channel

Inspections Before Shooting

(6) Time Code and User Bit-Related Inspections

- 1** Set the user bit as necessary
 - See “Setting the User Bit” (page 78) for a description of setting methods
- 2** Set the time code
 - See “Setting the Time Code” (page 77) for a description of setting methods
- 3** Set the F-RUN/R-RUN switch to R-RUN
- 4** Press the VTR START button
Check that the tape runs and the counter display number changes
- 5** Press the VTR START button again
Check that the tape stops and the counter display number stops changing
- 6** Set the F-RUN/R-RUN switch to F-RUN
Check that the counter display number changes regardless of the tape running status
- 7** Set the DISPLAY switch to UB
Check that the set user bit is displayed

Specifications

General

| | |
|------------------------------|---------|
| Power supply voltage: | DC 12 V |
| Power consumption | 23 W |

| | |
|----------------------------------|---|
| Operating temperature | 32°F to 104°F |
| Storage temperature | -4°F to 140°F |
| Operating humidity | Less than 85% (relative humidity) |
| Continuous operating time | Approx 90 min (using 1 Anton Bauer Trimpak 14 battery) |
| Weight | Approx 12.87 lbs (5.85 kg) (incl. main unit, viewfinder, lens, battery pack, tape and microphone) |
| Dimensions | 4½" (W) × 10¼" (incl. handle) (H) × 12⅞" (D) 119.2 × 255.5 × 326.3 mm |

Camera Section

| | |
|-----------------------------------|---|
| Pick-up devices | 1/2-inch on-chip FIT type of CCD |
| System | RGB 3-CCD system |
| Picture elements | 410,000 pixel |
| Spectral system | F1.4 prism system |
| Built-in filters | 1, 3200K 2, 5600K+1/4 ND 3, 5600K 4, 5600K+1/16 ND |
| Quantization | 10-bit A/D (R, G and B channels), 14.3 MHz |
| Digital signal processing | 16-bit long operation, 14.3 MHz/28.6 MHz |
| Programmable gains | 3 positions can be set from among -3, 0, 3, 6, 9, 12, 15, 18, 21, 24 and 30 dB |
| Shutter speeds | 1/100, 1/120, 1/250, 1/500, 1/1000 and 1/2000 sec Synchro scan mode, 1/30 4-1/57.4 sec, 1/61.7-1/250 sec |
| Lens mount | 1/2" Bayonet type |
| Sensitivity | F8 (2000 lux, 89.9% reflection) |
| Minimum subject brightness | 2 lux (F1.4, +30 dB) |
| Image S/N ratio | 62 dB |
| Horizontal resolution | 750 lines (center) |
| Vertical resolution | 400 lines (normal mode)/450 lines (Super V mode) |
| Registration | Below 0.03% (entire range) (excl. lens) |
| Geometric distortion | Below measurable limit (excl. lens) |

Viewfinder

| | |
|-------------------|--------------------|
| CRT | 1.5" monochrome |
| Resolution | 600 lines (center) |

Specifications

VTR Video System (during playback on a standard playback unit)

| | |
|---------------------|--|
| Bands | Brightness, 0 Hz to 5.75 MHz +1.0 dB/−3.0 dB |
| S/N ratio | 55 dB |
| K factor (2T pulse) | Within 2% |
| Y/C delay | Within 20 ns |

VTR Audio System (during playback on a standard playback unit)

| | |
|--------------------|---|
| Sampling frequency | 48 kHz (synchronized to video) |
| Quantization | 16-bits/sample |
| Frequency response | 20 Hz to 20 kHz ± 1.0 dB (at reference level) |
| Dynamic range | 85 dB or more (at 1 kHz, AWTD) |
| Distortion | Within 0.1% (at 1 kHz, operating level) |
| Wow/flutter | Below measurable limit |
| Head room | 20 dB |
| Emphasis | T1=50 μs, T2=15 μs (can be turned ON/OFF) |

VTR Tape Running System

| | |
|-------------------------|-------------------------------------|
| Tape speed | 33.820 mm/s |
| Recording/playback time | Approx. 63 min (using the AJ-P63MP) |
| FF/REW time | Approx. 3 min (using the AJ-P63MP) |

Connectors

Input

| | |
|--|--|
| AUDIO IN CH1/CH2 (XLR, 3-pin, male) | MIC/LINE switchable MIC, Menu setting to −60/−50/−40 dBu LINE, Menu setting to −6/0/+4 dBu |
| MIC IN (XLR, 3-pin, female) | Menu setting to −60/−50/−40 dBu, balanced 3 kohm |
| GENLOCK IN (BNC) | 1.0 Vp-p, 75 ohm |
| TIME CODE IN (12-pin) | 0.5 to 1.8 Vp-p, 10 kohm |

Output

| | |
|--|--|
| CAMERA OUT (BNC) | 1.0 Vp-p, 75 ohm |
| VIDEO OUT (BNC) | 1.0 Vp-p, 75 ohm |
| AUDIO OUT (XLR, 3-pin, female) | +4 dBu, balanced, low-impedance (Menu setting to CH1/CH2/MIX) |
| AUDIO CH1/CH2 OUT (12-pin, TC IN/OUT combined) | −20 dBu, unbalanced, low-impedance |
| VTR (26-pin, option) | |
| TIME CODE OUT (12-pin) | 1.0 Vp-p, 75 ohm |
| PHONES (mini-jack × 2) | |

Other

| | |
|--------------------------|---|
| DC IN (XLR, 4-pin, male) | DC 11 to 17 V |
| DC OUT (4-pin) | DC 11 to 17 V, maximum rated current, 0.1 A |
| LENS (12-pin) | |
| REMOTE (ECU, 6-pin) | |

Accessories

| |
|------------------------------------|
| Shoulder belt (1) |
| Sony battery connector, NP-1 screw |
| Video input connector (1) |

Weight and dimensions shown are approximate.
Specifications are subject to change without notice.

Power supply related

AU-BP220, AU-BP402 battery packs
AG-B425 battery charger (for charging the AU-BP220 and AU-BP402 battery packs)
AU-M402H battery case
AU-B110 AC adaptor

Video cassette tapes

AJ-P6MP, AJ-P12MP, AJ-P23MP, AJ-P33MP, AJ-P63MP metal tapes

Viewfinder

5-inch viewfinder

External VTR-related

Portable video cassette recorder
AJ-YA710P time code input/output/video input adaptor
AJ-YA700P 26-pin output connector (for connecting an external VTR to the 26-pin interface)
AQ-EC1 extension control unit
Connection cables

- for connecting an external VTR to the 26-pin interface
- for connecting an external VTR to the 14-pin/26-pin interface
- SHAN-C12TCA multi connector cable (complementary)

Audio components

AJ-MC700P microphone kit
Stereo microphone
AJ-MH700P microphone holder
WX-RA700 wireless receiver
WX-R980 camera attachment

Maintenance products

AJ-CL12MP cleaning tape
AJ-SC700 soft carrying case
SHAN-B700 carrying case (complementary)
SHAN-RC700 rain cover (complementary)

Panasonic

Broadcast & Television Systems Company

Division of Matsushita Electric Corporation of America

Executive Office

One Panasonic Way (4B-7), Secaucus, NJ 07094

Service Centers

Eastern One Panasonic Way Panazip (2A-4) Secaucus NJ 07094
(201) 348-7677 Fax (201)-348 7511

Southern 1225 Northbrook Parkway Suite #170 Suwanee GA 30174
(770)-338-6855 Fax (770)-338-6656

Western 4001 West Alameda Ave , Suite 100 Burbank CA 91505
(818)-562 1579 Fax (818)-562-6663

Parts Information & Ordering

9 00 am-5 00 pm (EST) (800)-334-4881/24 hr Fax (800)-334-4880

Technical Support

Emergency 24 hr Parts & Support (800)-222-0741

Training Information

Digital System Products (201)-392 6076

Service Literature

(201)-392-6281

Matsushita Electric of Canada Ltd

5770 Ambler Dr Mississauga, Ontario L4W 2T3 (905)-624-5010

Panasonic de Mexico S A de C V

Av angel Urreaza Num 1209 Col de Valle 03100 Mexico D F (52) 1 951 2127

Printed in Japan
VQT626B-3

F1295H3086 

